

Project:



**Scan for more info!**

Owners manual  
Quick install  
Quick sizing  
Install layout  
Parts list

## **CBR-V2-SDLX**

**Draft tower, 2 valves**  
**Sanitary dispense levers**



### **Self service sparkling & chilled still water, two faucet tower options:**

- CBR-V2C-SDLX Chrome finish
- CBR-V2BLC-SDLX Black chrome finish



### **Specifications**

- Flow rate is adjustable up to 2 oz per second and can be locked
- Ideal for self service; Cup push to dispense sanitary levers
- ADA friendly: sanitary lever lowers activation point of the faucet by 6.25"
- Self-closing faucets with downward pointing nozzles
- Bottle filling clearance: 12.375"
- Tower height (including 4" handles): 21"
- Ergonomic grip handles or SS knobs
- Supplied with quick connect fittings for easy hook-up to our CR-4L38 trunkline
- Comes with base gasket for water tight seal to counter
- For use and pairing with all Crysalli remote chillers
- Weight: 12 lbs

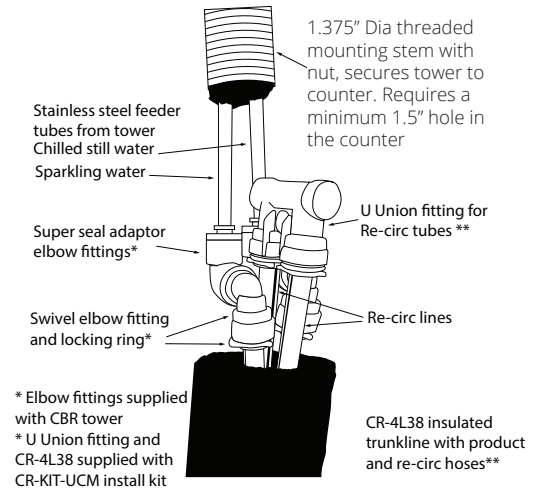
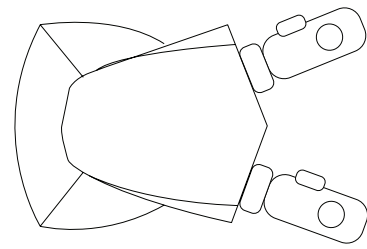
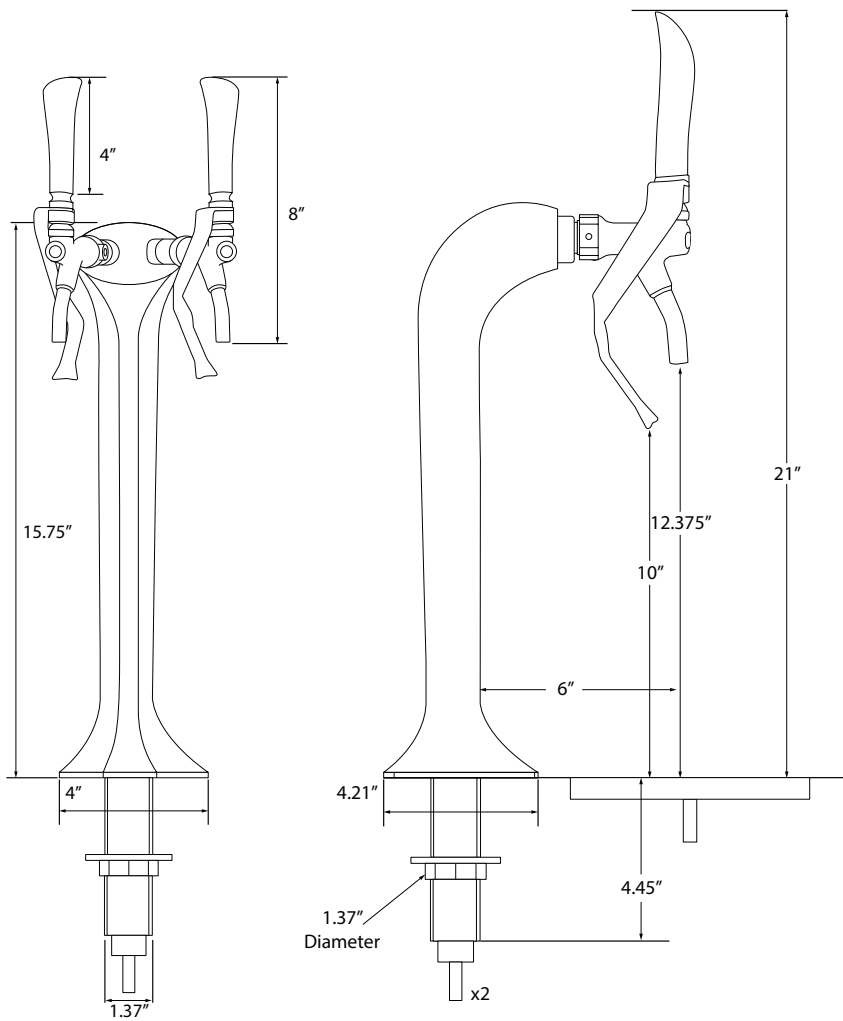

## Accessories

- **CR-100301-C**  
Optional chrome handles:



- **DP-CT**  
Drain pan countertop mount

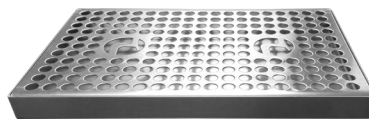

Configured with a 1/2" drain stem for direct plumbing

- **RDP-1SSQ-2CL**  
Recessed drain pan



Overall 12" Wide x 15.125" Deep  
Flush mount on counter with splash zone. Cup rest locators in drain grate. Requires square cut for drain pan and hole cut for tower

- **CR-MDLN-V2**  
Optional medallion kit:



- **DP-CT-LD**  
Drip pan, less drain, with rubber feet



- **CBR2-FKM-V2**  
Install fitting kit for connecting two CBR-V2 towers to one remote UCM chiller

