

Project:



Scan for more info!

Owners manual
Quick install
Quick sizing
Install layout
Parts list

CBR-V1C-MINI-SSX **Short height tower**



Sparkling or chilled still water
Single faucet tower

Specifications

- Flow rate is adjustable to your liking and can be locked in a specific setting
- Faucet flow rate: 1.5-2 oz per second
- One faucet for sparkling or chilled still water
- Height: 13.5"
- Bottle filling clearance: 5.5"
- Ergonomic handles
- Supplied with quick connect fittings for easy hook-up to our CR-4L38 trunkline
- For use and pairing with all Crysalli Remote Chillers
- Low profile design for positioning the tower over sinks, low overhead cabinet space, or on tall counters
- Weight: 8 lbs

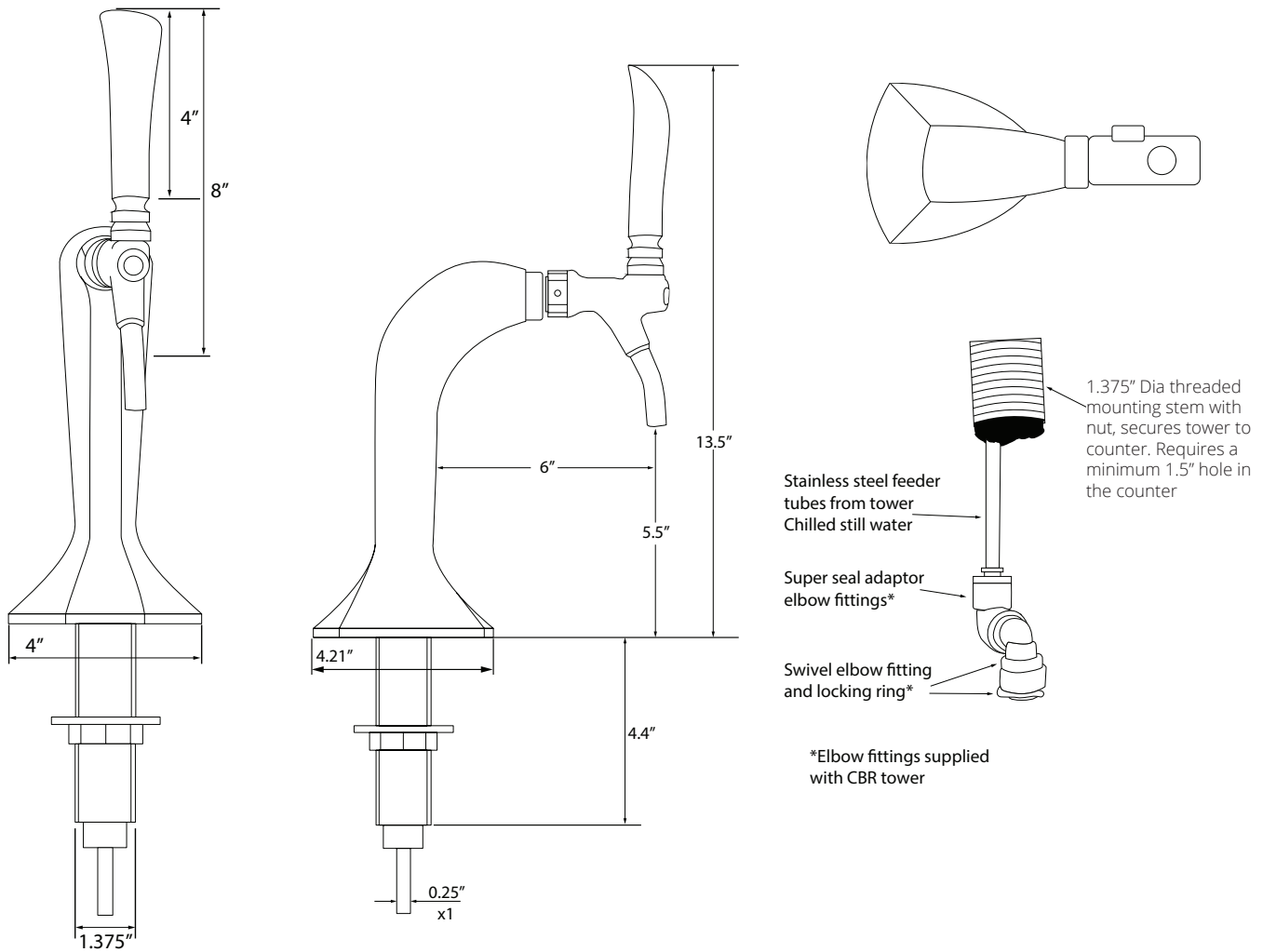

Accessories

□ CR-100301-C

Optional chrome handles:



□ CR-MDLN-V1

Optional medallion kit:



□ DP-CT

Stainless countertop mount drain pan



Configured with a 1/2" drain tube for direct plumbing

□ DP-CT-LD

Drip pan, less drain, with rubber feet



□ CBR2-FKM-V2

Install fitting kit for connecting two CBR-V2 towers to one remote UCM chiller



□ RDP-1SSQ-1CL

Recessed drain pan



Overall 12" Wide x 15.125" Deep
Flush mount on counter with splash zone. Cup rest locators in drain grate. Requires square cut for drain pan and hole cut for tower



BIM | CAD | MOBILE

