

CR-X3PB-COMP

Three Push-Button Single Spout Tower



Three push-button, single spout tower designed for dispensing sparkling water, chilled still, and ambient water in residential applications. Features an elegant, handmade turned brass bar in chrome finish with stainless steel and plastic internal components. Designed to pair with low-volume Crysalli remote chillers.

Features

- In-line flow rate control
- Swiveling nozzle for ideal dispensing position
- 3 push-to-dispense buttons and engraved water type symbols
- Bottle filling clearance: 9"-10"
- Tower height: 12.6"
- Supplied with quick connect fittings
- Ideal for over-sink mount and self-service applications
- For use with low-volume Crysalli remote chillers

Accessories

- Drain pans:
 - DP-CT: Stainless countertop mount drain pan, 1/2" direct-plumb drain tube
 - DP-CT-LD: Drip pan, less drain, with rubber feet



CR-X3PB-COMP

Three Push-Button Single Spout Tower



Scan for more resources!

Line Drawings

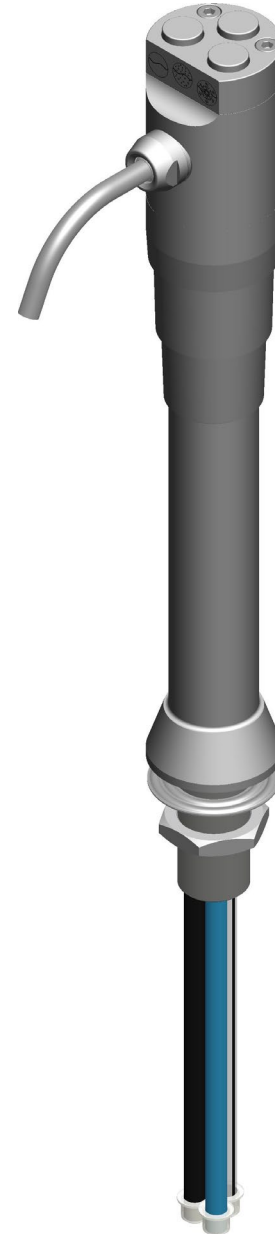
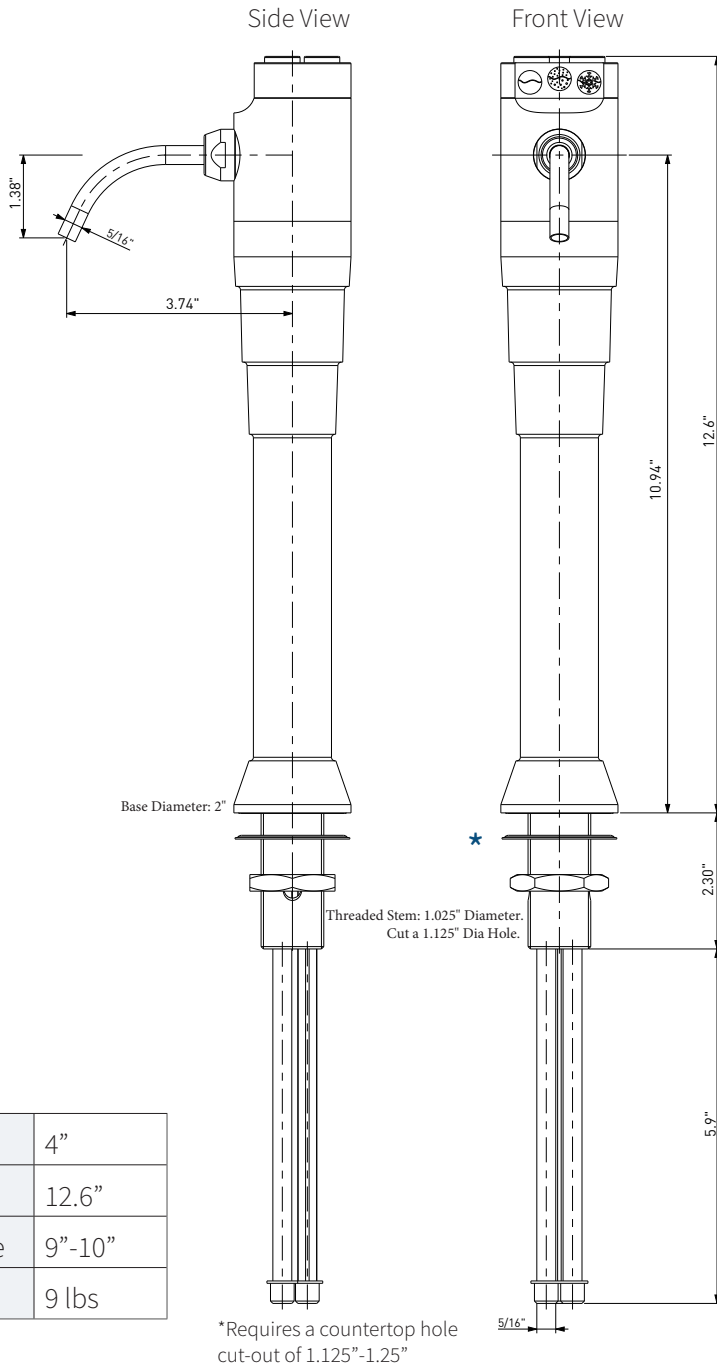

Width	4"
Height	12.6"
Bottle fill clearance	9"-10"
Weight	9 lbs

Includes in-line compensator for flow control tuning of sparkling water.

