

AQUAZONE UNDERCOUNTER STILL CHILLED WATER SYSTEM



PROJECT:

ITEM NO & SPEC DETAILS:

CR-UCW

CBR-V1 or CM-1

CR-24FC



Ideal for:

- Fresh Drinking Water Programs at Schools.
- Cafeterias
- Restaurants.
- Hotels

Towers Sold Separately



CBR-V1

- Elegant Cobra Style Chrome Tower.
- High flow faucet.
- Flow adjustment control.
- Great for front of house, Full Service.

Or



CM-1

- Sanitary Push Button dispenser.
- Built in drain pan
- Tall 10" opening to fit re-usable bottles, carafes and cups.
- Perfect for Self Service



Water Filtration System (sold separately)



CR-24FC

SPECIFICATIONS: CR-UCW

Self-contained Refrigeration system.

12" Wide x 18.75" Deep x 24.5" High

Electrical: 120 Volts - 3 Amps

Compressor: 1/5 H.P.

Water Bath: 4 Gallons

Ice Bank: 9.5lbs

Weight: 115 lbs

130 Drinks per hour @ 40° or less



AquaZone is made up of three components:

Select one of the two tower options.

CBR-V1

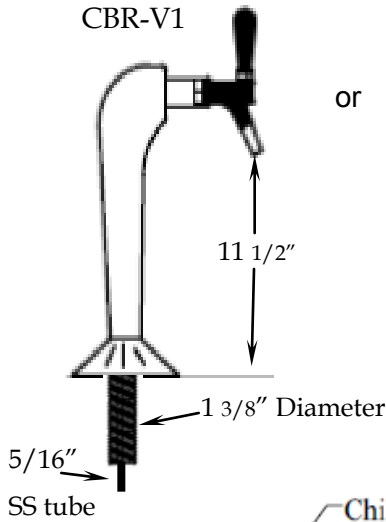

or

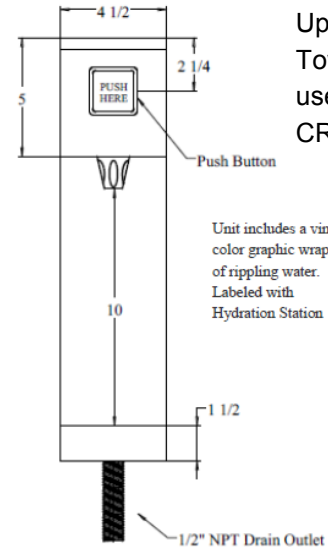
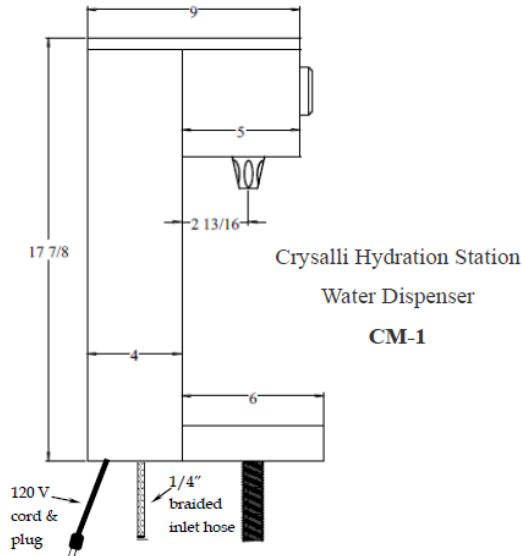

Up to Two CM-1 Towers can be used with a CR-UCW.

Unit includes a vinyl color graphic wrap of rippling water. Labeled with Hydration Station

Chilled Water and Cooling Water Outlets. John Guess

Note: Water Inlet 1/4" Flexible Tubing, Condensate Drain Hose 3/8" Flexible Tubing and Power Cord. Bottom Front.

CR-UCW

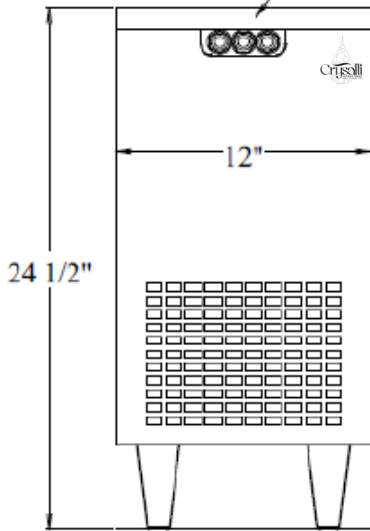

Black Vinyl exterior finish

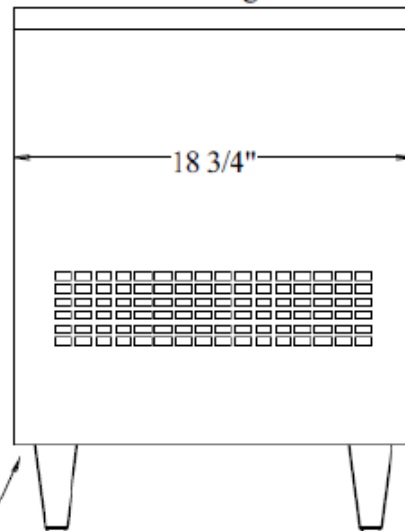

Evap Coil

Note: Allow 6" of clearance around unit

- 7' incoming water (1/4")
- 7' Overflow Drain hose.
- 9' 120v Electrical cord.
- 4" Legs.
- Use Install Kit: CR-Kit -SW for fittings
- Allow for rear & side clearance around unit for air flow.
- Allow for lid removal and

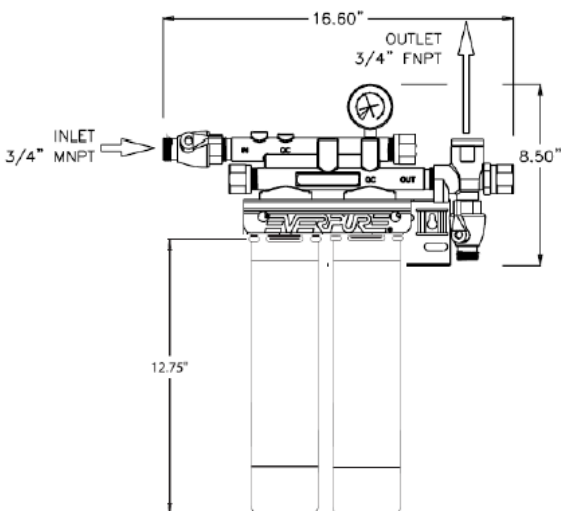

CR-24FC Twin system

- 16.6"W x 5.5:D x 19.25"H
- Inlet Connection: 3/4"
- Outlet Connection 3/4"
- Flow Rate: 5 GPM
- Rated Capacity: 30,000 gal
- Pressure Requirements: 10-125 psi

NSF Certified under NSF/ANSI Standard 18



Made in the USA

800-229-4410

www.crysalli.com