



CR-1SW Countertop &
CR-UCW Undercounter Still Water Chillers
Installation & Service Manual



IMPORTANT: This manual is a guide for installing, operating, servicing and maintaining this equipment. Refer to Table of Contents for page location of detailed information to answer questions that arise during installation, operating, service and maintenance, or installation of this equipment.

TABLE OF CONTENTS

	PAGE
PREFACE	1
CHAPTER I <u>GENERAL DESCRIPTION</u>	2
SYSTEM DESCRIPTION	2
DESIGN DATA	3
MODEL LINE DRAWINGS	4
CR-1SW EXPLODED VIEW	5
DESCRIPTION, EXPLODED VIEW, CR-1SW	6
CR-UCM1 EXPLODED VIEW	8
DESCRIPTION, EXPLODED VIEW, CR-UCW	9
COMMON PARTS LIST	11
ELECTRICAL SCHEMATIC, DIRECT WIRE	12
ELECTRICAL SCHEMATIC, S-68-B	12
THEORY OF OPERATION	14
CHAPTER II <u>INSTALLATION</u>	17
UNPACKING AND INSPECTION	17
SELECTING LOCATION	17
LOCATION RECOMMENDATIONS AND HINTS	18
SAMPLE INSTALL DRAWING	18
CR-UCW INSTALLATION	20
CR-UCW INSTALL DIAGRAM	21
CR-1SW INSTALLATION	22
CR-1SW INSTALL DIAGRAM	23
INSTALL WATER FILTER ASSEMBLY	25
INSTALL WATER PRESSURE REGULATOR, (OPTIONAL)	25
INSTALL DRAIN LINE	26
CONNECTING WATER INLET	26
CONNECTING CBR-V2 DRAFT TOWER	27
ELECTRICAL REQUIREMENTS	29
CHAPTER III <u>PREPARATION</u>	29
PREPARING SYSTEM FOR OPERATION	29
PREPARING AND STARTING REFRIGERATION UNIT	29
ADJUST WATER FLOW RATE	29
CHAPTER IV <u>OPERATORS INSTRUCTIONS</u>	30
DAILY PRE-OPERATION CHECK	30
COOLING UNIT MAINTENANCE	30
CHECKING WATER BATH	30
CHANGING WATER BATH	31
ADJUSTMENTS	31
ADJUSTING WATER FLOW RATE	31
SELF SERVE X0101-HEX FAUCET ADJUSTMENT	32
CHAPTER V <u>SERVICE AND MAINTENANCE</u>	33
PERIODIC INSPECTION AND CLEANING	33
DAILY CLEANING	33
WEEKLY CLEANING	33
MONTHLY CLEANING	33
CR-UCW CABINET MAINTENANCE	34
CR-1SW CABINET MAINTENANCE	34

TABLE OF CONTENTS (cont'd)	PAGE
CLEANING CONDENSER COIL	34
CHECKING/CHANGING WATER BATH	35
WATER PUMP MAINTENANCE	35
CHANGING WATER FILTER CARTRIDGE	36
SANITIZING PROCEDURES	37
CHAPTER VI <u>TROUBLESHOOTING</u>	38
CARBONATOR	38
WATER PUMP MOTOR WILL NOT OPERATE	38
WATER PUMP MOTOR WILL NOT SHUT OFF	38
WATER PUMP WILL NOT SHUT OFF AND PRESSURE RELIEF ENGAGED.....	38
SHORT CYCLING OF WATER PUMP MOTOR	38
WATER PUMP CAPACITY TOO LOW.....	38
WATER PUMP OPERATES BUT WATER PUMP DOES NOT PUMP	38
FROZEN WATER BATH.....	38
COOLING OR CONDENSING UNIT NOT OPERATIONAL.....	38
AGITATOR MOTOR NOT OPERATING	38
COMPRESSOR DOES NOT OPERATE	38
COMPRESSOR WORKS CONTINUOUSLY BUT DOES NOT FORM SUFFICIENT ICE BANK.....	39
COMPRESSOR WILL NOT STOP AFTER SUFFICIENT ICE BANK IS PRODUCED	39
CONDENSER FAN MOTOR NOT OPERATING	39
NO WATER BEING DISPENSED.....	39
DISPENSED PRODUCT CARBONATED TO LOW	39
DISPENSED PRODUCT MAKES FOAM AS IT LEAVES NOZZLE	40
DISPENSED PRODUCT COMES OUT CLEAR BUT FOAMS WHEN IT TOUCHES CUP OR GLASS	40
NOTE SECTION	41
WARRANTY BOND	42

PREFACE

Crysalli is manufactured on behalf of Western Pacific Distributors by International Carbonic Inc.

INTERNATIONAL CARBONIC INC. has enjoyed over 53 years of manufacturing excellence in the field of carbonation and in the beverage related industry. They have had a long and proud history with quality as their standard and innovation as their goal. They enjoyed patents on the first Sodajet type carbonator. This method of carbonation instantaneously carbonated the water to 100% saturation. They developed the first patented dispensing valve to dispense bulk beverage with carbonation equal to or in excess of bottled beverages. A valve with three flavors and soda was another first. They were the first to incorporate the total postmix package, i.e., carbonation, refrigeration, and the ability to dispense from one self contained unit. They have pioneered many such firsts and will continue to develop advanced systems for the future, such as electronic interrogatable portion controls to electronic liquid level controls.

CHAPTER I

GENERAL DESCRIPTION

This chapter gives the description, theory of operation, and design data for the CR-1SW and CR-UCW Crysalli units and related components.

SYSTEM DESCRIPTION

The Crysalli CR-UCW series of Undercounter Artisan Water units are a configuration of cold dispensed still filtered water, requiring a draft tower or faucet to dispense the product. These units have a water bath derived re-circulation system to help maintain product temp between chiller and tower.

The Crysalli CR-1SW series Still Water Countertop Artisan Water units are configured to dispense cold still filtered water directly from the taps on the unit. Both taps dispense cold water.

The CR-1SW and CR-UCW units consist of a condensing unit, a manual fill water reservoir, water-cooling coil, an agitator/re-circulation pump, and cooling coil(s). The unit will freeze over 1/3 of the reservoir/bath water to create an ice bank. This ice bank is responsible for maintaining a 32 degree reservoir water temp. The cooling coils and submerged in the reservoir/bath water to chill and maintain ice cold product temperatures.

For proper function the Crysalli units must have a filtered water supply, and electrical supply and drainage. Other items that will be required are the Draft tower, water filtration system, and installation kit.

WARNING: Before shipping or relocating a Crysalli into a freezing ambient environment empty still and carbonated water. Ice bank melted, and water drained from water bath. A freezing ambient environment will cause existing water in unit to freeze possibly resulting in damage to pump/motor assembly, water coil, water bath, valve(s), etc.

TABLE I - I
DESIGN DATA

COOLING UNIT

Overall cabinet dimensions:	<u>CR-1SW MS</u>	<u>CR-UCW LF-R</u>
Height	24 ½"	21"
Width	12 ¼"	12"
Depth	19 ¾"	18 ¾"
Weights (lbs):		
Shipping	80	120
Dry weight	65	105
Operational Weight	100	120
Ice Bank	10	17
Capacities: CR-1SW		
Unit water bath (no ice bank)		3 gallons
Refrigerant requirement (R-134-A)		165 grams
Compressor		1/5 hp, 2200 btu
Ambient operating temperature		40 F to 100 F.

Capacities: CR-UCW		
Unit water bath (no ice bank)		4 gallons
Refrigerant requirement (R-134-A)		165 grams
Compressor		1/5 hp, 2200 btu
Ambient operating temperature		40 F to 100 F.

Electrical Requirements: The cooling unit requires a 115 VAC, single phase, 60 Hertz Power circuit.

	CR-1SW	CR-UCW
Ampacity	9.6	9.6
Condensing Unit	2.1	2.1
Water/Recirc. Pump Motor	6.2	6.2
Agitator	.8	.8

Water Filter Required: CR-24FC, CR-27FCP or other approved filter system

Incoming Water Pressure Regulator (Optional)	Pressure 40 – 65
--	---------------------



DISPENSING VALVES Ambient Operating Temperature	32 F to 100 F
---	---------------

Electrical Requirements: Operating Voltage	24VAC, 60hz
--	-------------

Crysalli AquaZone Still Water Chiller (Undercounter)

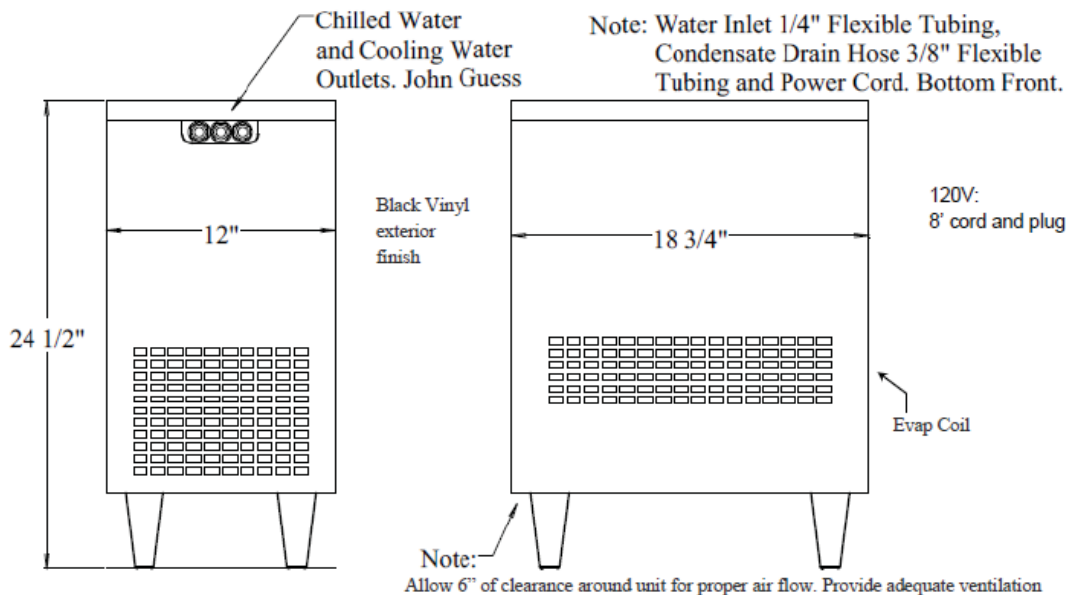

CR-UCW

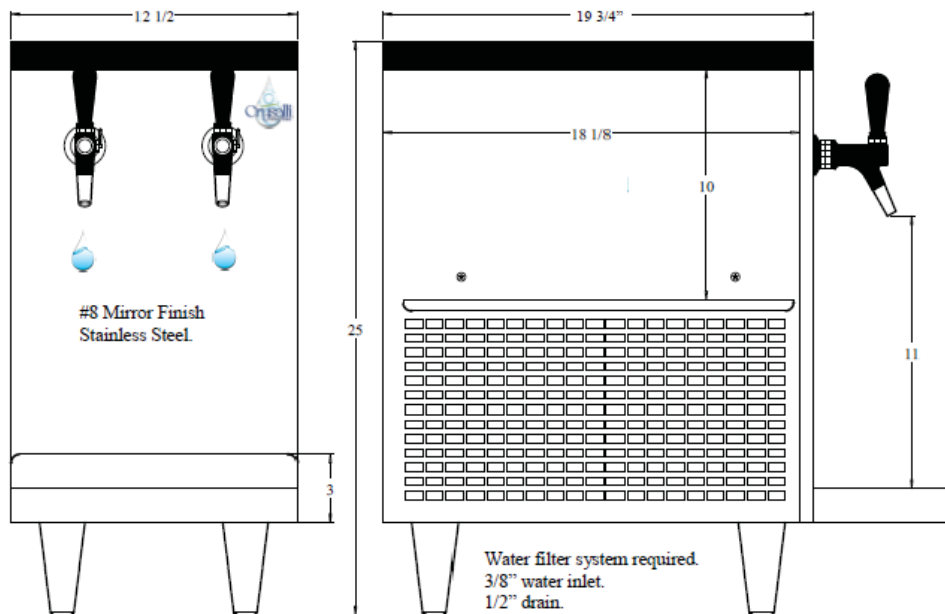

 	Draw Rate	1.5 - 12 oz/min	Total Drinks < 40	130
	Compressor	1/5 hp	Ice Bank	17 lb.
	Water Bath	4 Gallons	Electrical	120 Volt 60 Hz 3 AMP
	Carbonator	n/a	Shipping Weight	120 lb.
		n/a	Dry Weight	105 lb.

CR-1SW Still Cold Water Dispenser



 	Draw Rate	1 - 12 oz/min	Total Drinks < 45	105
	Compressor	1/5 hp	Ice Bank	10 lb.
	Water Bath	3 Gallons	Electrical	120 Volt 60 Hz
	Specify Self Service or Full Service. S.S usage comes with Hex locking flow adjustment faucets		Shipping Weight	80 lb.
			Dry Weight	65 lb.

CR-1SW

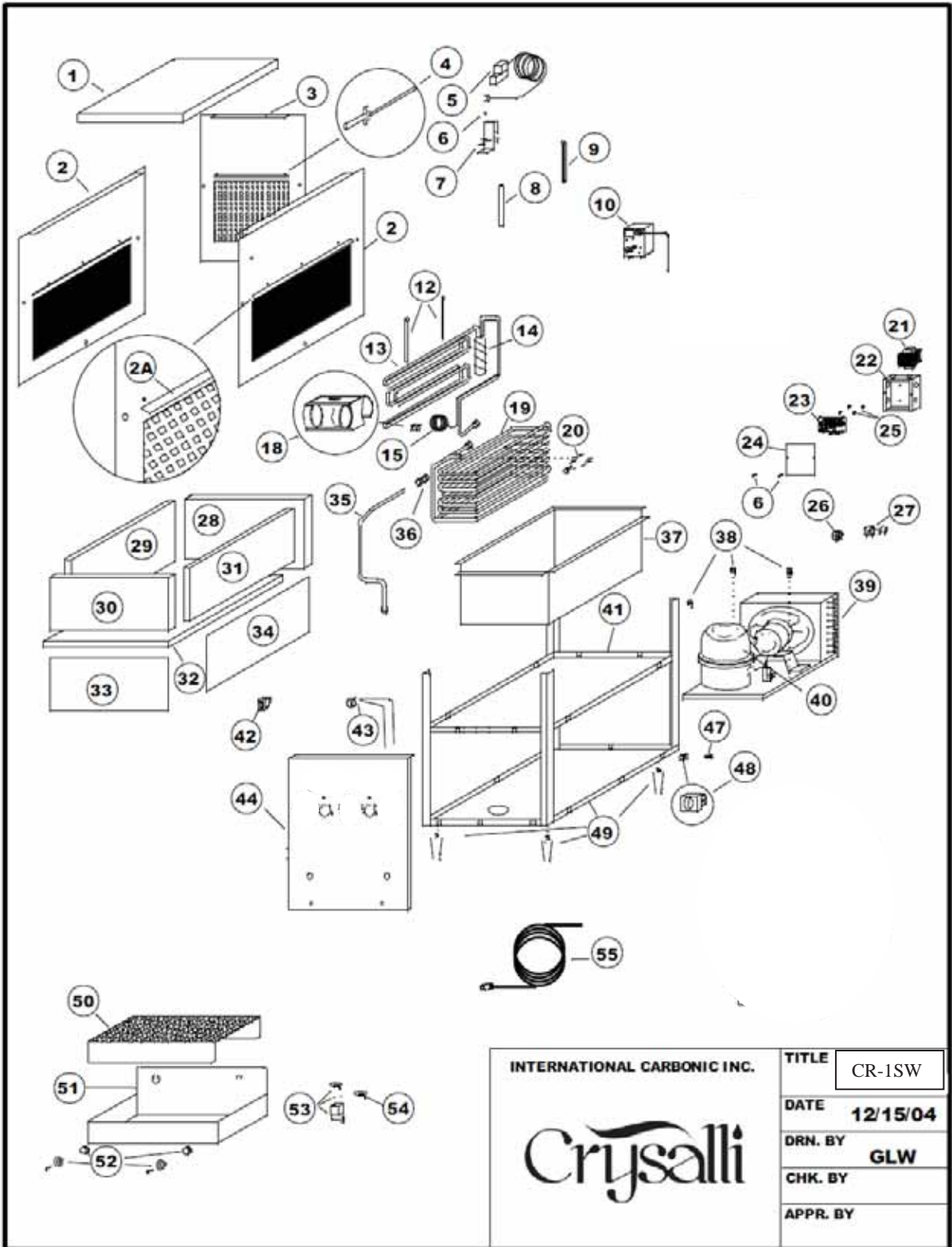

INTERNATIONAL CARBONIC INC. 	TITLE	CR-1SW
	DATE	12/15/04
	DRN. BY	GLW
	CHK. BY	
	APPR. BY	

CR-1

SYM	QTY	PART NO.	DESCRIPTION
1	1		LID W/INSULATION
2	2		SERVICE PANEL, SIDE
2A	2		SERVICE PANEL AWNING, SIDE
3	1		SERVICE PANEL, REAR
3A	1		SERVICE PANEL AWNING, REAR
4	7	A0051-A	RIVETS, BLACK
5	1	S0513-A	ICE BANK CONTROL
6	3	A0020	8-32 X 3/8 T.H. SCREWS, S.S.
7	1	S1304-U	ICE BANK CONTROL BRACKET
8	1	S0739	STAND PIPE, 6 1/2", WHITE
9	1	S0738	OVERFLOW, 6 3/4", GRAY
10	1	S0835	AGITATOR PUMP
11	1	S0073-48	PROBE ASSEMBLY
12	2	S0741	EVAPORATOR COIL RETAINER
13	1	S0733	EVAPORATOR COIL ASSEMBLY
14	1	S0509	ACCUMULATOR, 4" VERTICAL
15	1	Z0009	CAP TUBE, 12' - .042
17	1		
18	3	H0020	"T" CLIP 3/8 X 5/16
19	1	S0684	WATER COIL, COPPER
20	1	S0208-A	WATER REGULATOR, OPTIONAL
21	1	E0476-A	TRANSFORMER
22	1	S1308	TERMINAL BOX WITH COVER
23	1	S0068-B	LIQUID LEVEL CONTROL, LLC
24	1	S1310	TERMINAL BOX COVER
25	4	S1335	TERMINAL BOARD SPACER, NYLON, 3/8"
26	7	S0046	BUSHING
27	1	E0664	STRAIN RELIEF
28	1	MOISTURE BARRIER, 12
29	1	INSULATION, LEFT
30	1	INSULATION, REAR

CR-1 Cont.

31	1	INSULATION, FRONT
32	1	INSULATION, RIGHT SIDE
33	1	INSULATION, BOTTOM
34	1	MOISTURE BARRIER, 23
35	1	S0667	WATER LINE, COPPER
36	1	S0203	UNION CONNECTOR
37	1	S0731	BUCKET COMPLETE W/INSULATION
38	3	A0046	5/16 X 18 FLANGE WHIZ LOCK SCREW, 3/4"
39	1	AEA1360YXAXA	CONDENSING UNIT, 1/5 H.P.
40	1	AEA1360YXA	COMPRESSOR ONLY
41	1	S0732	FRAME, COMPLETE
42	1	S0783	UNIT ON OFF SWITCH
44	1	S0769-5	VALVE PLATE
45	11	A0014	SCREW, #10 X 1/2", TH SS
46	5	PFC-II-QR	DISPENSING VALVES
47	20	A0048	SCREW, #10 X 1/2", TH SS
48	16	S1325	SQUARE GROMMET NUT
49	1	S0765	LEGS, 4", SET OF 4
50	1	S1149-A	CUP REST
51	1	S1149	DRAIN PAN W/CUP REST
52	1	S0743	DRAIN PAN HARDWARE, SET
53	1	S1161	PLASTIC DRAIN OUTLET, 90 DEGREE
54	1	S1162-A	FLANGE PLUG
55	1	E0141-12	CORD
56	1	S0175	90 DEGREE ELBOW, 3/8 MP X 1/4 MF
57	1	S0103	PUMP PROTECTOR
58	1	S0170	HALF UNION BRASS, 3/8 MF X 3/8 MP
59	1	S0104	PUMP PROTECTOR BRACKET
60	1	S0650	STRAINER, BRASS
61	2	A0045	5/16 X 18 FLANGE WHIZ LOCK SCREW, 1/2"
62	1		
63	1	S0106	CLAMP, V BAND
64	1	S0096	MOTOR, CARBONATOR

CR-UCW

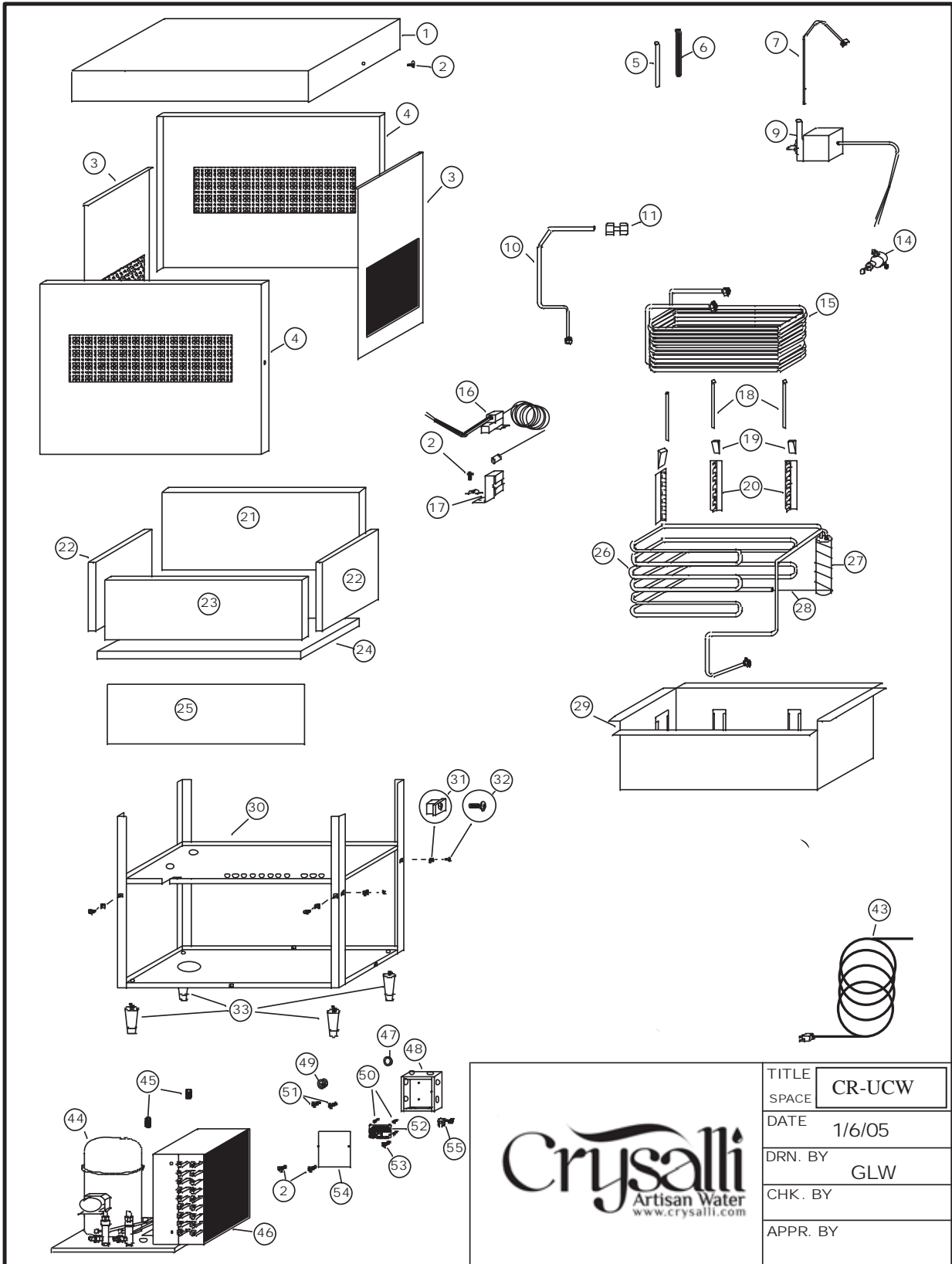

TITLE	CR-UCW
SPACE	
DATE	1/6/05
DRN. BY	GLW
CHK. BY	
APPR. BY	

CR-UCW

SYM	QTY	PART NO.	DESCRIPTION
1	1	S0680	LID ASSEMBLY
2	4	A0020	SCREW, 8-32 X 3/8 T.H., S.S.
3	2		SERVICE PANEL, SIDE
4	1		SERVICE PANEL, LARGE, FRONT & REAR
5	1	S0657	STANDPIPE, 7 3/4"
6	1	S0658	OVERFLOW, 8"
7	1	G0016	TY-RAP LARGE
9	1	S0840	AGITATOR PUMP
10	1	S0668	WATER LINE, COPPER
11	1	S0203	UNION
14	1	S0208-A	WATER REGULATOR, OPTIONAL
15	1	S0666	WATER COIL W/YOKE
16	1	S0513-A	ICE BANK CONTROL
17	1	S1304-U	ICE BANK CONTROL PROBE BRACKET
18	5	S0661	EVAPORATOR COIL RETAINER
19	5	S1323	EVAPORATOR GUIDE WEDGE
20	5	S0662	EVAPORATOR COIL SUPPORT BRKT
21	1	BEADBOARD, SIDES
22	1	BEADBOARD, BACK
23	1	BEADBOARD, FRONT
24	1	BEADBOARD, BOTTOM
25	1	MOISTURE BARRIER

CR-UCW Cont.

SYM	QTY	PART NO.	DESCRIPTION
26	1	S0663	EVAPORATOR ASSEMBLY
27	1	S0509	ACCUMULATOR
28	1	Z0010	CAP TUBE, 9' - .050
29	1	S0656	BUCKET COMPLETE W/INSULATION
30	1	S0655	FRAME, COMPLETE
31	12	S1325	SQUARE GROMMET NUT
32	12	A0014	SCREW, #10 X 1/2" PH T.H., S.S. COMBO
33	1 SET	S0765	LEGS
41	1	S0106	CLAMP, "V" BAND CLAMP
43	1	E0141-9	CORD
44	1	AEA3440YXA	1/3 H.P. COMPRESSOR ONLY
45	2	A0046	5/16 X 18 FLANGE WHIZ LOCK SCREW, 3/4"
46	1	AEA3440YXAXL	1/3 H.P. CONDENSING UNIT
47	2	S-7/8	HOLE PLUG
48	1	S1308	CONTROL BOX W/COVER
49	5	S0046	BUSHING
50	4	S1335	TERMINAL BOARD SPACER, NYLON, 3/8"
51	2	A0049	8-32 X 3/8 PH, TYPE F. SELF TAP
52	1	S0068-B	LIQUID LEVEL CONTROL
53	1	A0067	8-32 X 3/8 HEX HD, PH GREEN GROUND SCREW
54	1	S01310	CONTROL BOX COVER
55	1	E0664	STRAIN RELIEF

Common parts list for both Models

Item No.	Description
N0032	Fan Motor
S0068-B	Liquid Level Control
S0073-48	Probe, Carb Tank
Z0009	Cap Tube CR-1 & CR-UC1
S0513-A	Ice Bank Control
S0783	Switch, On/Off
S0835	Agitator Pump
S0840	Agitator/Circulator Pump
X0101	Blk Speedy Valve
X0101-HEX	Blk Speedy Valve w/Hex
X0102	Speedy Valve fitting
X0101-CRM	Chrm Speedy Valve
	SS Still Water Valve
10-2381-80	Adjusting Screw Lever
10-2256-80	Adjusting Screw Hex
	O-Ring Clear, CBR Tower
S0275	Flow Adjuster, inline block
S1318-SET	Adjustable cushion feet
0747-SET	4.25" Legs kits set

S-68-B

ELECTRICAL SCHEMATIC 120 VOLT

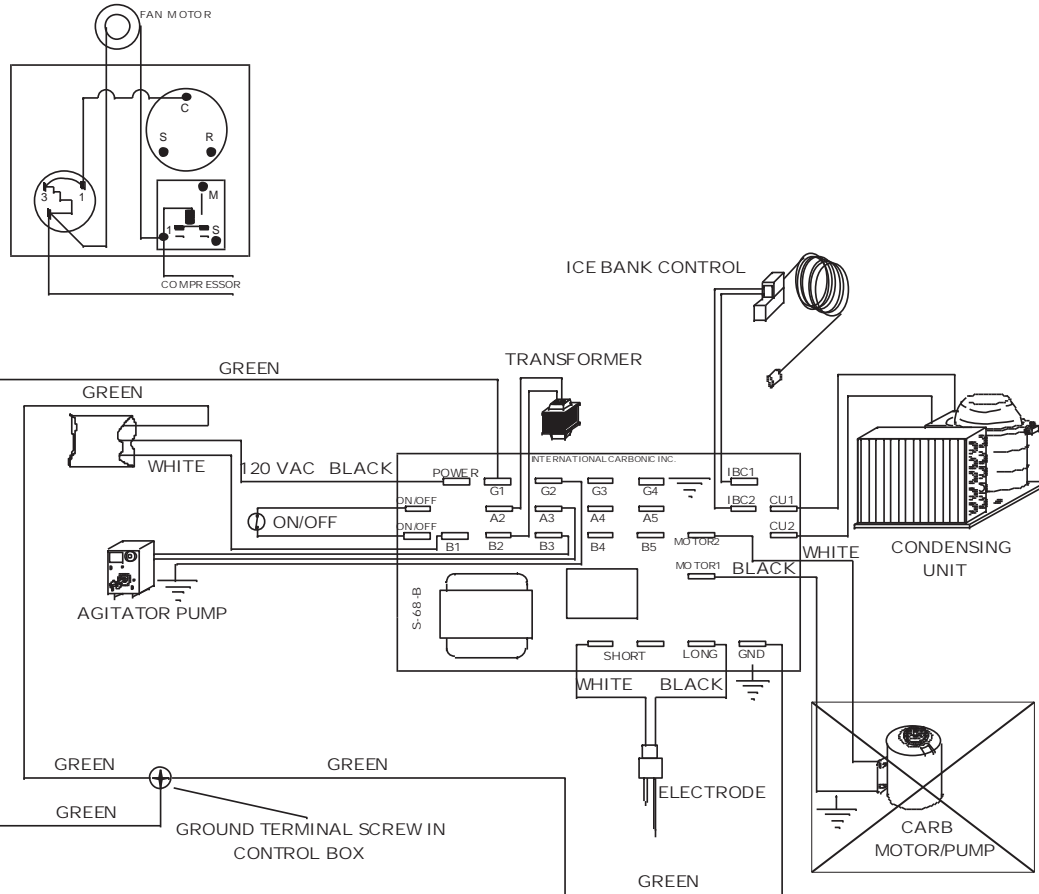

Note: Ground Terminals, Carbonator Tank

and Water Bath Must be

Commonly Grounded

NOTE: IF USING EXTRA 120V. ACCESSORIES SUCH AS RECIRCULATING MOTOR, ILLUMINATION ETC., MAKE CONNECTIONS AT TERMINAL A4, A5 FOR POWER/BLACK LEG. TERMINALS B4, B5, FOR NEUTRAL/WHITE LEG AND GROUND AT BOX OR ANY GROUND TERMINAL NOT IN USE. TERMINALS GROUND TERMINALS ARE G1, G2, G3, G4.

THEORY OF OPERATION

The Crysalli was designed to manufacture and dispense carbonated and non-carbonated water much like your local bottling plant that cans or bottles your favorite carbonated or non-carbonated water.

Initially water is chilled and then carbonated to dispense a quality drink. To chill the water the water is routed through a water coil that is submerged in an ice-cold water bath. The temperature of the incoming water is at ambient temperature as it enters the water coil. As the incoming water passes through the water coil the heat is removed from the water in the water coil and chilled to a temperature acceptable for a quality drink (34-36 degrees target). The chilled water is now routed into a carbonator tank where this ice cold water is mixed with CO₂. This water is now transformed into a carbonic acid, (sparkling water) and ready for dispensing. Optionally the cold sparkling water and still can be plumbed to the Carbonation Adjustment Valve (S-0270) which blends still water into the sparkling water to achieve a specific bubble texture and size.

The units contain a water bath. A certain amount of this water will be transformed into ice. This water reserve and ice bank will act as a reservoir for refrigeration. This reserve is utilized during peak periods when the BTU output of the compressor is not sufficient to meet the demand of the draw. An Ice Bank Control (IBC, S-0513A) senses the level of the ice and turns on or off the refrigeration system. The IBC has a sensing bulb, cap tube and controller. There is a fluid in the bulb that expands when the bulb is covered in ice. This pushes fluid through the cap tube that pushes a diaphragm that activates the switch. Once ice is dissipated from the bulb the fluid backs off deactivating the switch.

It should be recognized that without refrigeration your carbonation system would not produce a drink that will hold carbonation. There is a direct relationship between dispensed temperature and the volumes of CO₂ that can be held in liquid form.

The following will give a general overview of the flow of individual circuits and a clearer understanding of our mini bottling plant.

Carbon dioxide gas (CO₂) passes from a CO₂ cylinder through high-pressure regulator. The high-pressure regulator regulates the CO₂ feeding the Crysalli and should be set at 55-75 PSI. The gas, after leaving the high-pressure regulator goes to the carbonator tank. This gas must be at a pressure greater than the incoming water by at least 25-PSI to assure the proper function of the carbonator

As discussed earlier plain water enters the Crysalli through the incoming water line. This water proceeds through the water coil where it is chilled prior to entering the carbonator tank or in the case of non-carbonated water chilled prior to going directly to a valve. Prior to entering the carbonator tank the chilled water goes through another regulator. This assembly is utilized to maintain water pressure feeding a non-carbonated valve when used in conjunction with carbonated valves.

The incoming water source should be regulated as well, this is normally performed by the use of an in line water regulator provided in the install kit (50 psi). If the water is not regulated and the water pressure is equal or greater than the incoming CO₂ the act of carbonation will be greatly inhibited or completely eliminated.

At the proper settings, the gas pressure will stop the water from entering the carbonator tank. To force the water into the tank a liquid level control and motor/pump will be used. This combination will force the water into the tank mixing the water and CO₂ together.

The carbonator utilizes a Soda Jet Recirculating Principle. This process was pioneered in the early 1950's. This principle produces instantaneous carbonation at extremely large capacities of 100 gallons per hour minimum.

The level of the carbonated water within the stainless steel mixing tank is used to operate the motor driven pump. The liquid level control, in conjunction with a probe housed in the carbonator tank, controls the pump motor. The motor will come on when the carbonated water within the mixing tank recedes to a predetermined low level and stops the pump motor when the carbonated water reaches a predetermined high level.

During the cycle of operation, fresh water enters the carbonator tank through the soda jet after passing through the water pump. The water pump has impellers, which drives the water through the water coil then a dual check valve and then through the soda jet and into the carbonator tank.

The position and angle of the soda jet is fixed to direct an extremely high velocity solid jet of fresh water so as to impinge upon the surface of the stored body of carbonator water within the stainless steel mixing tank. The force created by this jet of fresh water entering the mixing tank causes all the water within to cascade and foam through the carbon dioxide gas area in a continuous recirculating-manner.

This action causes a breakdown of the surface tension of the water, forming numerous minute gases filled water bubbles. The micro thin walls of these water bubbles surrounded by gas both inside and out, offer maximum water surface for the absorption of the gas. The size opening through this jet permits large volumes of water to be carbonated.

As the incoming water is being carbonated, the level within the tank rises to contact the upper probe tip, which will de-energize a relay on the liquid level control and stop the motor from turning the pump. This motor will be inactive until water within the tank recedes below the long probe tip, at which time, the relay on the liquid level control will close, engaging the motor once again.

REMOTE CIRCULATING COOLING SYSTEM (in the CR-UCW only)

The remote station circulating cooling system is used as its name implies to cool the water, and soda water lines between the dispenser and the remote stations.

The cooling is accomplished by circulating the water from the cold water bath of the dispenser through tubing to the remote station and then returning this partially warmed water to the water bath.

When installing stations remote from the dispenser cabinet, the following operations are very important:

Location of the Cabinet: - Locating the dispenser cabinet properly depends upon two factors: convenience to the user and convenience of installation and service.

If cabinet is not used as a serving station it is permissible to place it in a basement, back room, or any other out of the way place. However, it is important to locate the cabinet as close as possible to the remote station in order to keep the heat loss through the insulated extended lines at a minimum. When used as a serving station, it is necessary to place the cabinet where it will be most accessible to the operator.

Water shut off valves and power switches should be located as near the cabinet as possible in order to facilitate service. Where an air-cooled condenser is used, there should be enough space surrounding the cabinet to insure adequate air circulating through the refrigeration condenser. Space should also be provided if possible, for doing service work on the cabinet. Note: when units are located in isolated rooms outside ventilation is necessary and air conditioning is recommended.

CAUTION: In order to have even distribution of cold water, the cold-water circulating lines must always be run in series even on multiple station installations.

IMPORTANT: Be sure to leave all connections and fittings exposed until after the entire system has been pressure tested.

In order to insure maximum heat transfer between the braided plastic lines (through which the water and soda are carried) and the circulating tubing, it is necessary to tape these lines firmly together.

It is of utmost importance that the extended lines of the remote installation be properly and adequately insulated. Failure to do this will cause overloading of the refrigeration unit and ice bank, condensation on the outside of the insulation and reduced cold drink dispensing capacity.

CAUTION: All open ends, joints and connections of the insulation must be sealed air tight to prevent outside air from entering the insulated duct. Outside air, which contains moisture, would condense this moisture within the insulation duct resulting in the insulation becoming wet, which would reduce its insulating qualities. Water dripping from duct would also result.

Attention must be given to avoid restrictions in the lines, which may cause a reduction in pressure upon the carbonated water and allow some of the gas to escape from the carbonated water in the lines.

The pressure is measured on pounds per square inch and is the reduction in pressure within the carbonated water line between the carbonator outlet and the valve inlet while carbonated water is being drawn.

The amount of pressure drop will vary with the length of the line, size of the tubing used, (inside Diameter), the rise of the line, and the flow of the carbonated water through the line, (gallons per hour).

Braided Plastic Tubing – The flexible braided plastic tubing is used for carbonated water.. It will withstand high pressure and is easily installed because of its flexibility but should never be used in contact with hot water or steam lines.

CHAPTER II

INSTALLATION

This chapter covers unpacking and inspection, selecting location, installing CR-UCW and related components, connecting water inlet and electrical requirements.

UNPACKING AND INSPECTION

Upon receiving unit, immediately remove unit from shipping carton and inspect for shipping damage.

NOTE: Before leaving the factory all CR-UC# units were carefully inspected and the carrier has accepted and signed for them. Any damage or irregularities should be noted at the time of delivery and immediately reported to delivering carrier. Request a written inspection report from claims inspector to substantiate any necessary claim. File claim with delivering agency, not International Carbonic Inc.!

Unpack LOOSE-SHIPPED PARTS. At this time make sure all parts listed are present and in good condition. If any parts are missing, notify factory.

TABLE 2-1

LOOSE - SHIPPED PARTS

Item No.	Name	Qty
1	Installation/Service Manual	1
2*	High Pressure CO2 Regulator CR-3471	1
4	6" Gas Line (Inner Braid)	1
5**	Water Pressure Regulator 50 psi	1
6	Water filter Manifold -CR24FC	1
7	Water Filter Cartridges (2) 4FC	2
8**	Back Flow Preventer	1
9**	John Guest, Barb Fittings & Clamps	Lot
10	CBR-V2C Draft Tower (w/ CR-UCW only)	1
10B*	(optional) CBR-V1C Draft Tower	2
11	Drip Tray (w/ CR-UCW only)	1

* Optional, ** Included in CR-KIT-UCM or CR-KIT-CT

SELECTING LOCATION

IMPORTANT: Ambient temperature for CR-1SW and CR-UCW should not exceed 100 degrees "F." Operation of cooling unit in ambient above 100 degrees "F" can and will contribute to early failure of condensing unit and poor quality of finished product. Poor Ventilation of unit in a cabinet will also contribute to similar effects.

LOCATION RECOMMENDATIONS FOR CR-UCW AND HINTS

1. Place in a well-ventilated area, so the unit can properly receive air and exchange hot air out. Position the front side out, with the condenser coil air filter positioned for easy access to remove and clean.
2. Position unit as close as possible to proper electrical source, 120V 60HZ.
3. Position unit with a minimum of 6" space between bulkhead and cabinet for sufficient ventilation (cool air in and hot air out). Make sure the cabinet is ventilated. Poor ventilation can cause the unit to overheat and shut down or have poor performance characteristics, or result in short compressor life. Allow enough space at the top of the unit, between inside top of cabinet and unit for lid removal.
4. Position unit as close as possible to water source. Half-inch gate valve recommended for water connection.
5. Enough space must be allowed to install the water filter.
6. Position unit as close as possible to floor drain to route clear overflow tube to. Unit will primarily only drain water from this overflow tube at initial start-up as the water freezes to form the ice bank.
7. When the Trunkline is installed Vertically, greater than 10', the re-circ tubes may need to be primed (manually filled with water) before final connections are made at the highest point and the system is started up. This will help the re-circ pump from having to push the water up the vertical rise and ensure proper in and out recirculation of the bath water.

SAMPLE OF POSSIBLE INSTALLATION.(single Tower)

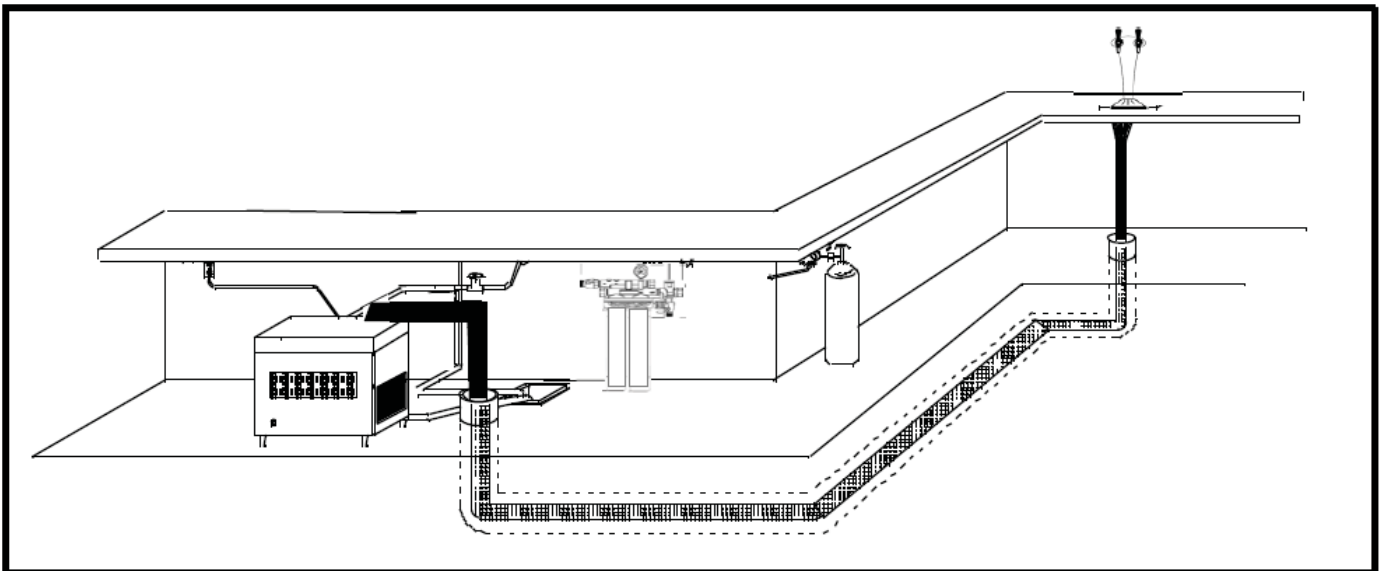



CR-UCM1 & CBR-V2 Sample Layout (not to scale)
 CR-UCM1: 12" W x 23.5 D x 24.5" H (with legs)

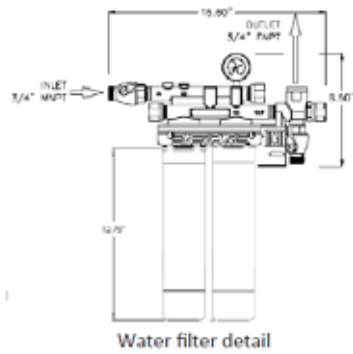
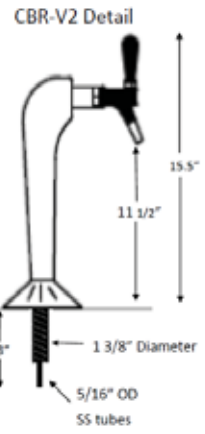

Threaded Shaft and tubing must either clear top of unit or sit off set of unit location for clearance. Minimum 10"

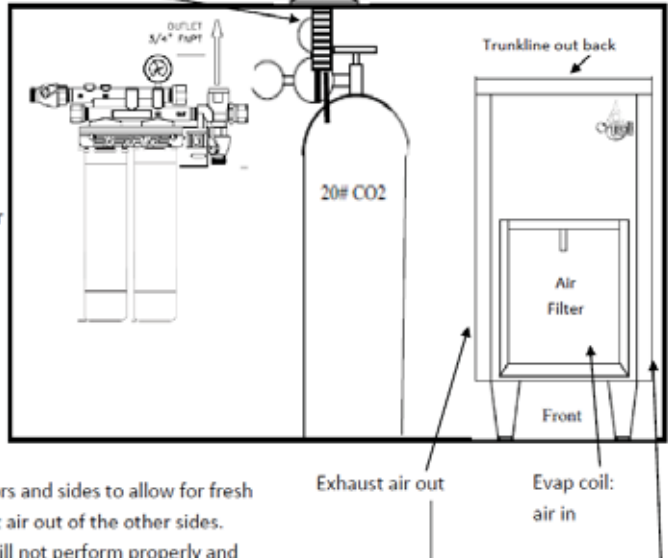
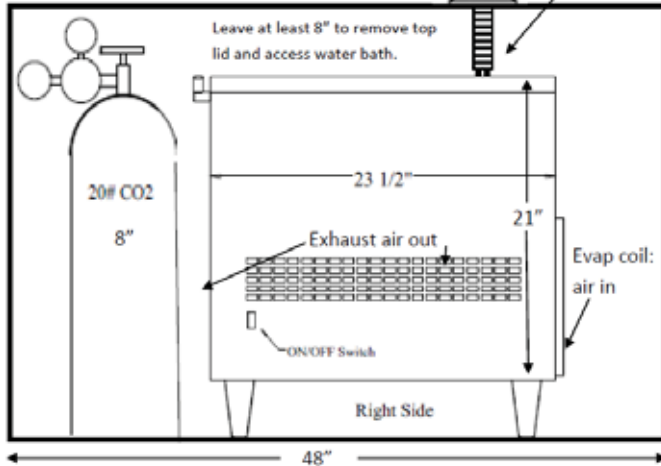

CO2 Tank Note: the typical 20 lbs CO2 tank is 8" in Diameter and 27.5" High. The CO2 Regulator will typically add 1" to the height and stick out 4"

Notes: Provide ventilated cabinet doors and sides to allow for fresh air into the Evap Coil side and Exhaust air out of the other sides. Without proper ventilation the unit will not perform properly and you will short life the compressor.

Top down view.
 Two Sample options in a 48"W x 24 and 28"D Cabinet

CBR-V2 draft tower needs 10" of bottom clearance for threaded shaft and connections.

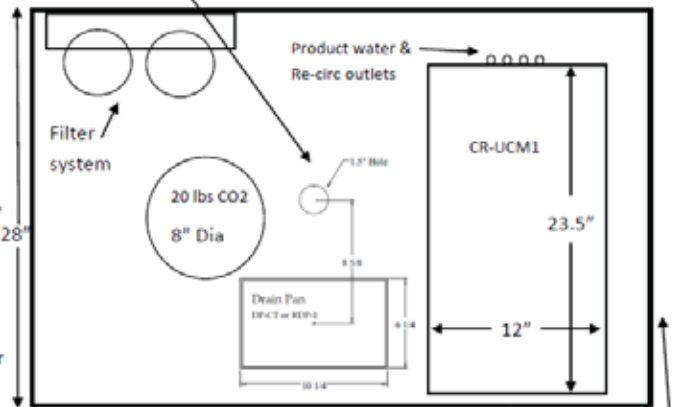
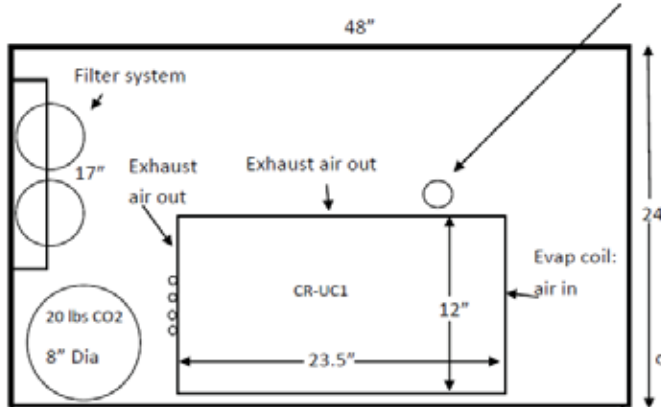

Ventilated/louvered doors

Ventilated/louvered doors and side panel

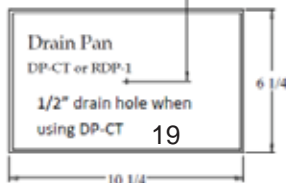

CBR-V2 Tower and Drain pan hole cut detail.

CR-UCW Undercounter Chilled Water Dispenser Install Guide

1. Select a counter location for your draft tower and an undercounter or remote location for your CR-UCW Crysalli unit. Place the CR-UCW unit as close as possible to water filter connection & 120-volt electrical outlet. Allow for good air ventilation and the evap side of the unit to face out, the unit will create heat and needs to have fresh air in and exhaust air out.
2. Mount the draft tower and drain pan or CM-1 push button tower. Plumb drain line from pan to the floor sink.
 - a. CBR-V1 Requires a 1 3/8" hole.
 - b. Drains Require 1/2" hole.
 - c. The CM-1 Push button dispenser requires 120v to run the valve.
3. **Outlet Connections:** Measure and Route the insulated trunk line (if required) from the CR-UCW unit to the location of the dispensing tower. The unit has three 3/8" John Guest bulk head connection on it. The center is the product outlet, and two outside connections are the inlet and outlet re-circ line connections.
4. **Product Outlet:** Connect a 3/8" line from the unit to the stainless steel lines on the CBR-V1 draft tower, or to the braided hose from the CM-1. Or adapt appropriately to dispenser inlet hook up.
5. **Re-Circulation lines:** Run the two re-circ line feeds from the unit up to the tower along with the product line, connect these two lines together at that point to create a continual loop with them from the unit and back. Flow these up as far as possible to the dispenser point of hook up. Cold water from the water bath will re-circulate through these lines to help keep the product line cold. If these lines are not going to be used they must still be capped or looped to each other at the bulk head fittings.
6. **Inlet Connection:** Connect the 1/4" braided water inlet line from the bottom of the CR-UCW unit to your water filter system. When using the Everpure Filter system, you'll need to reduce down from the 3/4" fpt inlet and outlet to accommodate your line size.
7. **Drain:** Rout Clear overflow drain line from the bottom of the unit to a floor sink or other waste drain. This is for overflow from the water bath.
8. Turn on the Water. Check all connections for leaks.

9. **Fill Water Bath:** Remove lid and fill water bath with non-filtered tap water, fill up to ¼" from top of the White standpipe (this is the over flow pipe to the clear drain hose).
10. Plug unit power cord into 120-volt outlet. Toggle the ON/OFF rocker switch to the ON position. Fan and compressor will turn on. Fan and Compressor will automatically turn off when a complete ice bank is made and cycle on and off to maintain it.
11. Check for leaks and wrap any exposed trunk line tubing with insulated foam tape.
12. Unit will take between 3 & 4 hours to make a complete ice bank.
13. Once unit has built the ice bank you are ready to dispense chilled still water.

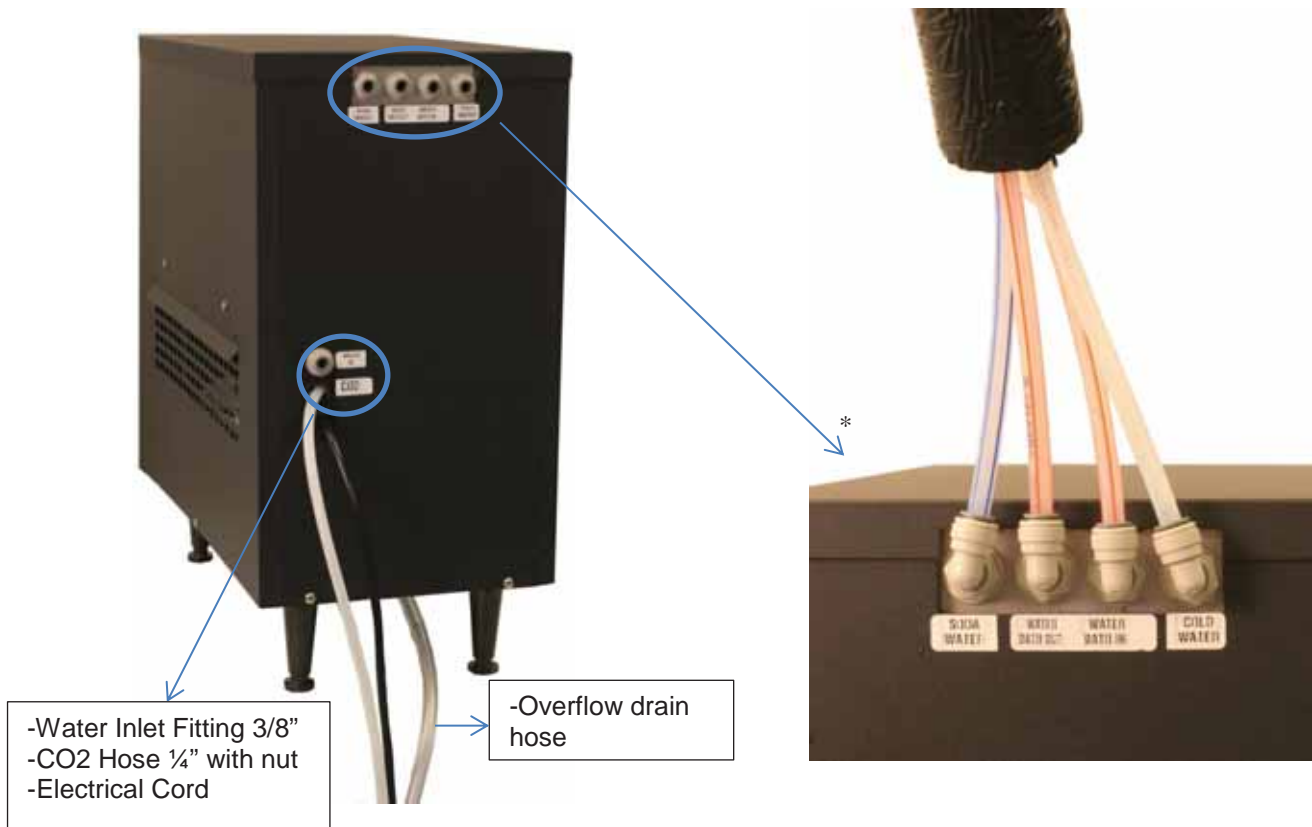

Under Counter Chilled Water Dispenser Quick Installation Guide

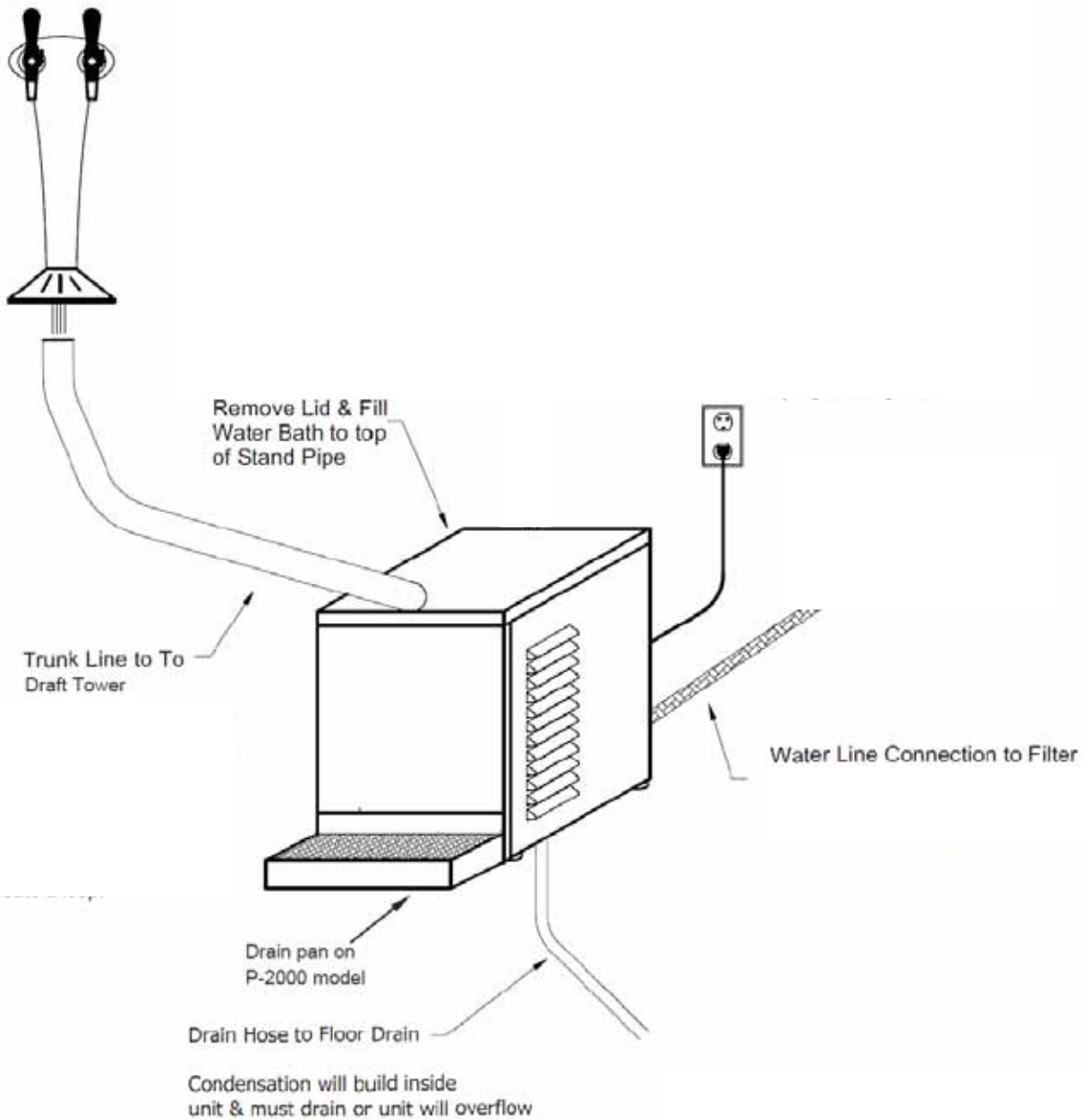

CR-1SW INSTALL Countertop

1. Select a location for your chilled water dispenser. Place unit as close as possible to water filter connection & 120-volt electrical outlet. Make sure there is sufficient space at the back and between the unit and walls and overhead for proper air circulation and to access the air filter.
2. Connect a 3/8" water line from your water filter system, then connect that line to the 3/8" push-in fitting at the bottom of the CR-1SW.
3. Turn on Water. Check connections for leaks.
4. Run clear overflow drain hose to floor drain or other waste drain.
5. **Fill Water Bath:** Remove lid of the unit and fill water bath with non-filtered tap water, fill to 1/4" from top of standpipe. This is the white tube in the water bath connected to overflow hose. The unit will not work without water bath filled.
6. Plug unit power cord into 120-volt outlet. Toggle the ON/OFF rocker switch to the ON position. Fan and compressor will turn on. Fan and Compressor will automatically turn off when a complete ice bank is made and cycle on and off to maintain it.
7. Unit will take between 3 & 4 hours to make a complete ice bank.
8. Pull open the still water faucets to run water through the system
9. Once unit has built the ice bank you are ready to dispense chilled still and



Chilled Water Dispenser Quick Installation Guide

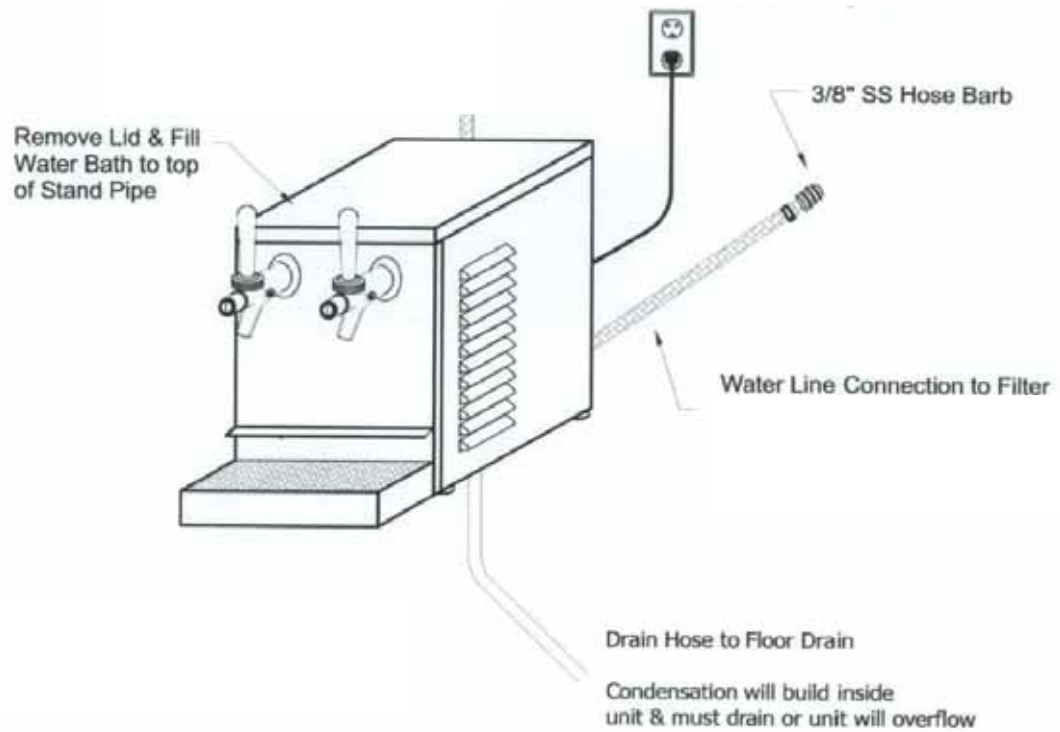

INSTALLATION Cont

INSTALL WATER FILTER ASSY.

1. Install water filter assembly on wall or other supporting structure.
2. Connect water filter assembly to inlet of valve on water supply line using minimum 3/8" I.D. water line. CR-24FC and CR-27FCP filter heads have 3/4" fmp and must be reduced down.
3. Connect water filter assembly outlet to CR plain water inlet fitting using minimum 3/8" I.D. water line. See CONNECTING WATER INLET.

When a water filter is used, it is important that it has a minimum 100 gallons per hour capacity and should be thoroughly flushed before it is connected to the water inlet connection.

WATER PRESSURE REGULATOR & BACK FLOW PREVENTER (OPTIONAL)

- If water pressure exceeds 90 psi, a water pressure regulator or water pressure-reducing valve may be installed *after the water filter* in the water supply line and adjusted to maintain a pressure of 60-75 psi. (The water regulator must have an orifice of at least 3/16" so as not to restrict the water flow through the valve. Valves that are built with 1/2" pipe thread connection usually have a sufficient orifice opening).

- Always reference local plumbing code for local standards about Back Flow Preventers such as need, installation placement and type of back flow preventer required.



Water Filter, Water Regulator & Back Flow Preventer install line drawing

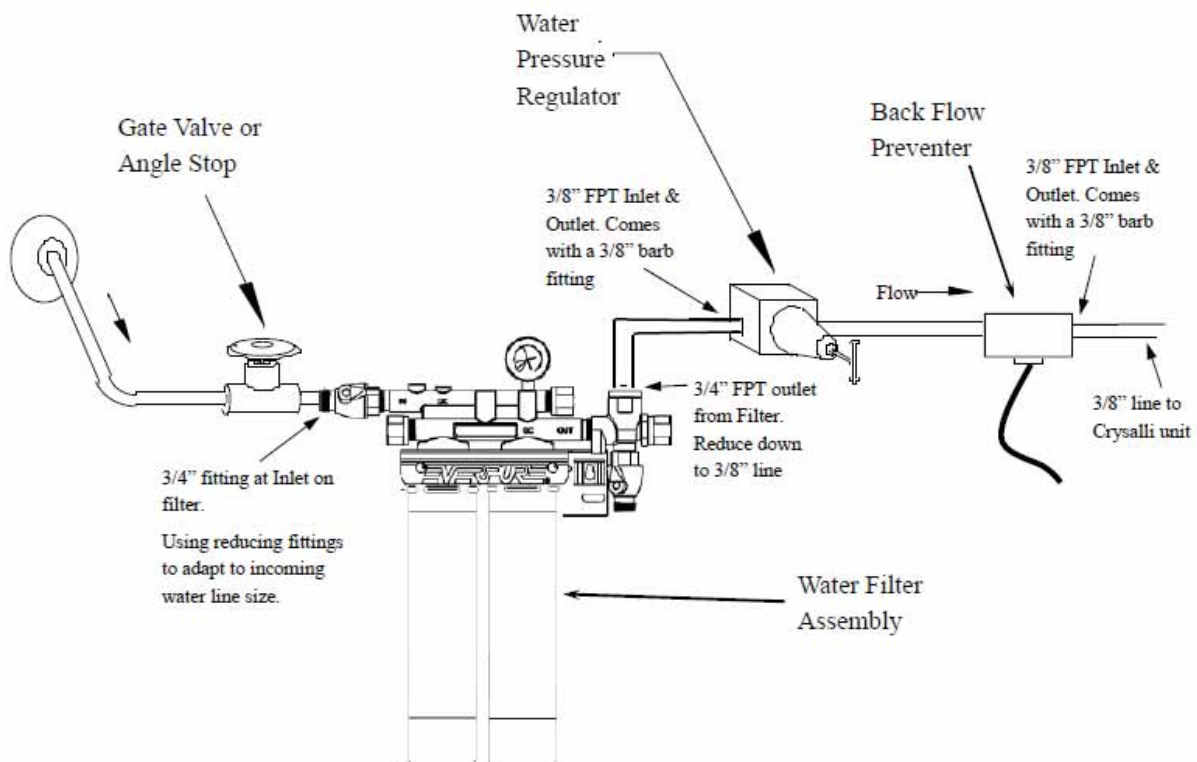

INSTALL OVERFLOW DRAIN LINE

1. Rout overflow drain hose or connect hose on CR-UCM# unit with drain using 1/2" I.D. clear plastic pipe or 1/2" copper or PVC to nearest outlet or floor sink to capture over flow water at start-up and for drain out of water bath for maintenance. If running to a floor sink run drain to local plumbing codes.
2. Do not reduce drain connection from cabinet outlet.
3. Water may drain from drain hose until ice bank has been completely made (2-3 hour for ice bank to form after initial start-up).
4. The over flow drain hose primarily functions to drain water at the initial startup as the bath water freezes and an ice banks forms which displaces the water level, pushing water up and out the over flow tube After a full ice bank is formed the unit will not drain water.

CONNECTING WATER INLET

WATER PIPE CONNECTIONS AND FIXTURES DIRECTLY CONNECTED TO POTABLE WATER SUPPLY SHALL BE SIZED, INSTALLED AND MAINTAINED ACCORDING TO FEDERAL, STATE, AND LOCAL LAWS.

The water connection on the CR-UCW and CR-1SW is made to a 3/8" John Guest Quick connect fitting. Due to the large capacity of the pump, any restriction of the incoming fresh water supply would starve the water pump and create noise within the pump, poor carbonation and extremely long running time.

After all primary water lines are made up, but prior to connecting water supply to cabinet, be sure to thoroughly flush all incoming water lines to remove all scale and any impurities that may be in the lines.

CONNECTING THE DRAFT TOWER (CBR-V2C) TO CR-UCW

The CBR-V2C draft tower contains two water lines plumbed to the faucets, one for carbonated sparkling water the other for still water. Connect these lines to the labeled braided lines from the trunk line, which extends from the CR-UCM1 unit. The CBR-V2C also has two re-circ line which should be connected to the clear re-circ lines also from the trunk line. Care should be taken to wrap any exposed lines with foam tape to insulate them.

SINGLE CBR-V2C TOWER INSTALL DETAIL

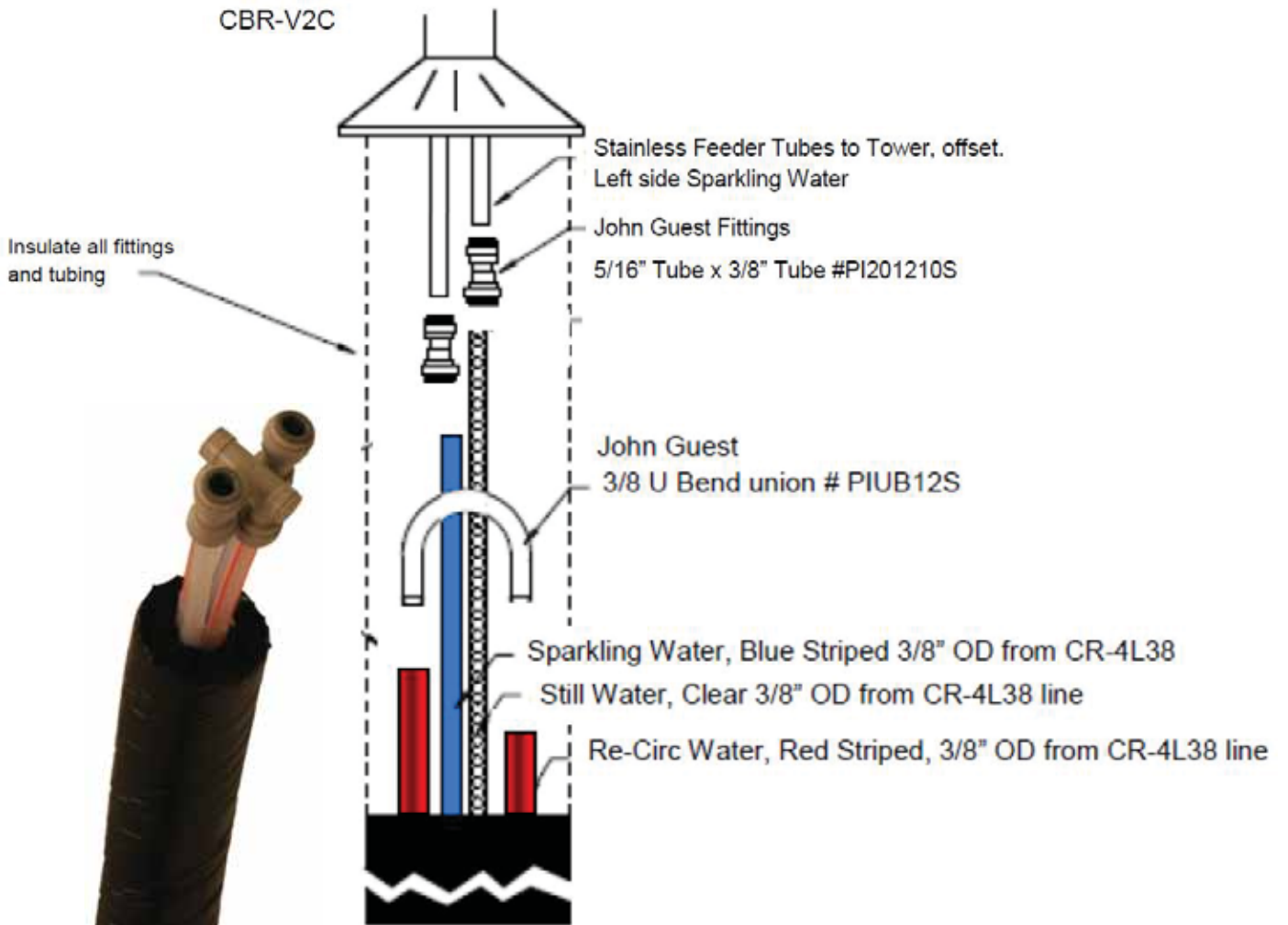

Teed 4L38 Trunk Line for Two CBR-V2C Tower Installation with CBR2-FKM Kit fittings

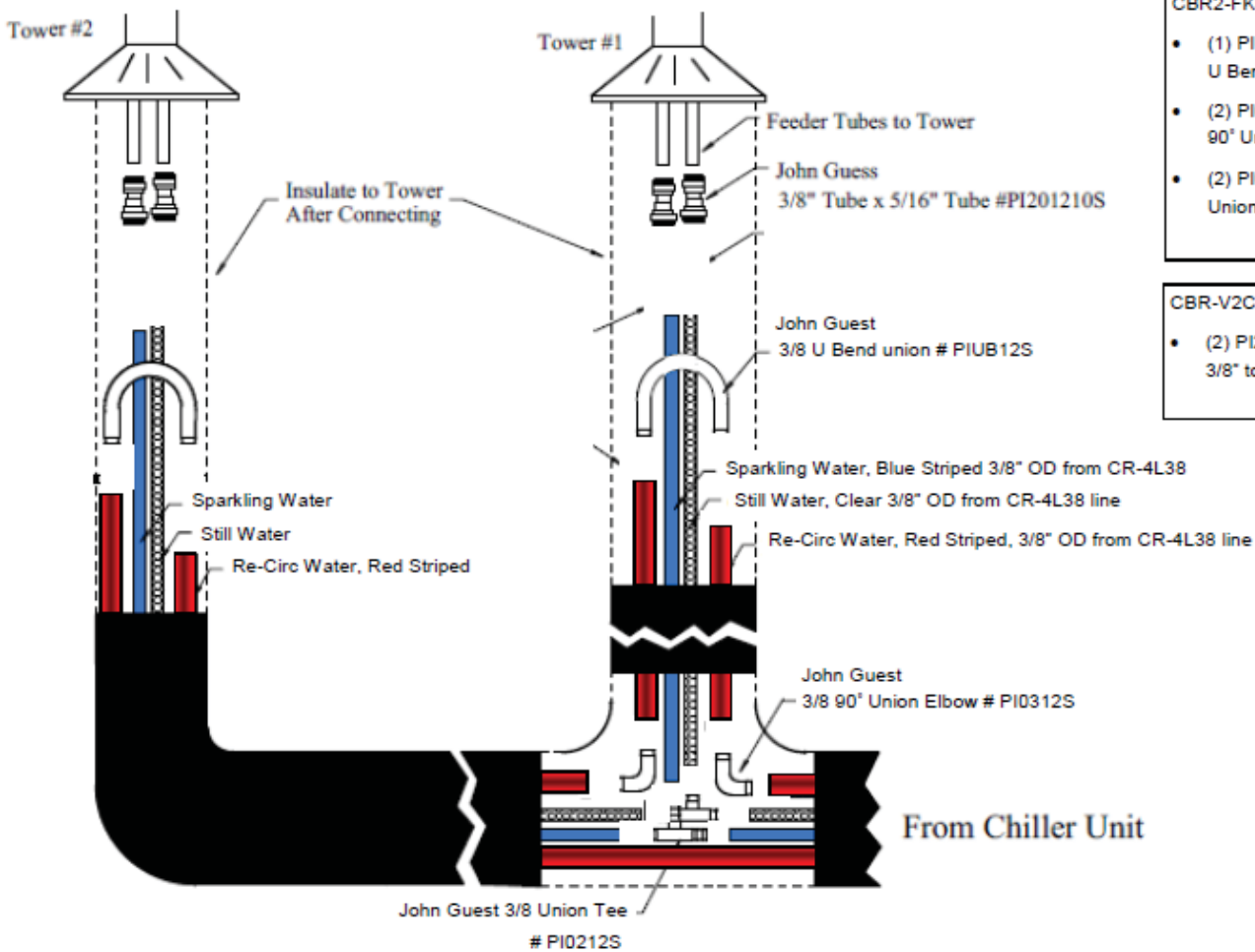

CBR2-FKM Install Kit:

- (1) PIUB12S 3/8" U Bend
- (2) PI0312S 3/8" 90° Union Elbow
- (2) PI0212S 3/8" Union Tee

CBR-V2C Tower:

- (2) PI201210S 3/8" to 5/16" union

RDP-1 Recessed Drain Pan for CBR-V2 and CBR-V1 Towers

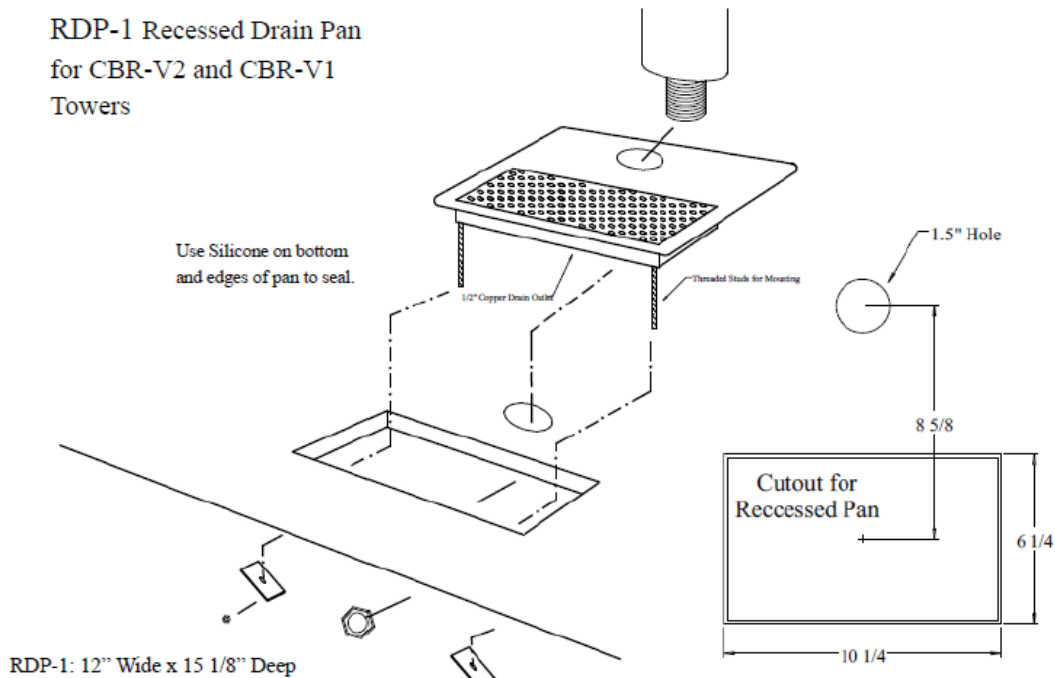

ELECTRICAL REQUIREMENTS:

The CR-UCW requires a 120 VAC, single phase, 60-Hertz power circuit, and must be wired in accordance with N.E.C. or local ordinance.

NOTE: Check CHAPTER I for running amperage and connect to appropriate electrical circuit.

CHAPTER III PREPARATION

All steps in previous chapters should be understood and carried out before proceeding.

PREPARING SYSTEM FOR OPERATION

Be sure that electrical power is unplugged, and valve on water supply line is closed.

PREPARING AND STARTING REFRIGERATION UNIT

1. CR-UCW refrigeration is pre-set at factory and ready to operate.
2. Remove lid.
3. **Fill water bath with clean water** up to ¼" from top of drain stand pipe or until water runs up and out of standpipe. (water will drain out of standpipe until ice bank is completely formed).
4. Open water inlet supply line.
5. Plug CR-1SW or CR-UCW power cord into electrical receptacle box. Make sure compressor, condenser fan motor, agitator motor start. The process of cooling the water bath will now commence. With ambient and water temperature of 75 degree "F" initial pull down or formation of complete ice bank will take approximately 5 hrs. When full ice bank has been formed, compressor and condenser fan motor will stop. Agitator will continue to operate, circulating water in water bath.

ADJUST WATER FLOW RATE

Control dispensing water flow rate at the faucets by adjusting the flow compensator valve handle on the right side of the faucets. Horizontal position is wide open, quarter turn is closed.

Control and Set incoming water pressure to CR unit via the Water Pressure Regulator.

CHAPTER IV

OPERATORS INSTRUCTIONS

This chapter covers operator's responsibilities for daily pre-operation check, adjustments, , cleaning, and sanitizing.

DAILY PRE-OPERATION CHECK

1. Make sure all fittings on faucets are tight and not leaking

COOLING UNIT MAINTENANCE

NOTE: Air circulation through the condenser coil, required to cool the condenser coil/compressor, is drawn in through grills on the cooling unit, through condenser coil and is exhausted out grills on the sides of the unit. Restricting air circulation through the cooling unit will decrease its cooling capacity.

To avoid needless and sometimes costly repairs, it is imperative to keep condenser fins clean. This may be accomplished by one of three methods. One method is use of a condenser brush (a longhaired, soft bristle brush) to gently sweep fins of condenser clean. Second method is to use a strong vacuum. The third method is to use CO₂ or an air hose to blow out condenser. The latter method should only be attempted after normal business hours to avoid dust contamination.

CHECKING WATER BATH

Periodically check water level in water bath. If it is low more water should be added as instructed for maximum product cooling. This dehydration will normally not occur in normal temperate climate zones. With normal humidity the opposite will occur therefore a condensate drain is installed. Any extra water in the water bath will exit the unit via the drain outlet. When unit is building its first ice bank it is normal to have water overflow the into the drain hose.

CHANGING WATER BATH

Drain water bath a minimum of twice a year. This can be accomplished by siphoning water with short hose into bucket or removing over flow standpipe. Once water is drained and ice bank is melted, water bath, water coils, bath walls, tank, etc. should be cleaned. Fill water bath to the top of the standpipe, (S-657).

ADJUSTING WATER PRESSURE

If adjustment of water flow rate should be necessary, turn the valve on the Water Pressure Regulator till the desired PSI is reached.
Check the Flow Control valve on the faucets as well to adjust the flow out of the faucets.

X0101-HEX Faucet Adjustment Instructions

The Faucets come with a flow rate control valve on each one of them. This valve is located on the right side of the faucet. It is designed to be adjusted and set via a Metric 2.5 allen hex wrench to a desired flow. Flow is typically set based on cup size being poured into. Adjustments can be made while the faucet handle is held open to visually see the flow setting.

With the Crysalli unit on and CO2 set appropriately, Adjust the valve to a full flow position, the valve then can be turned up or down within a quarter turn to lower the flow rate. Use a cup or carafe that you will be filling regularly to determine the best flow rate, or to minimize splashing.

Once set, tighten the outer ring with a wrench to lock the valve in place.

The valve may need to be periodically re-adjusted.

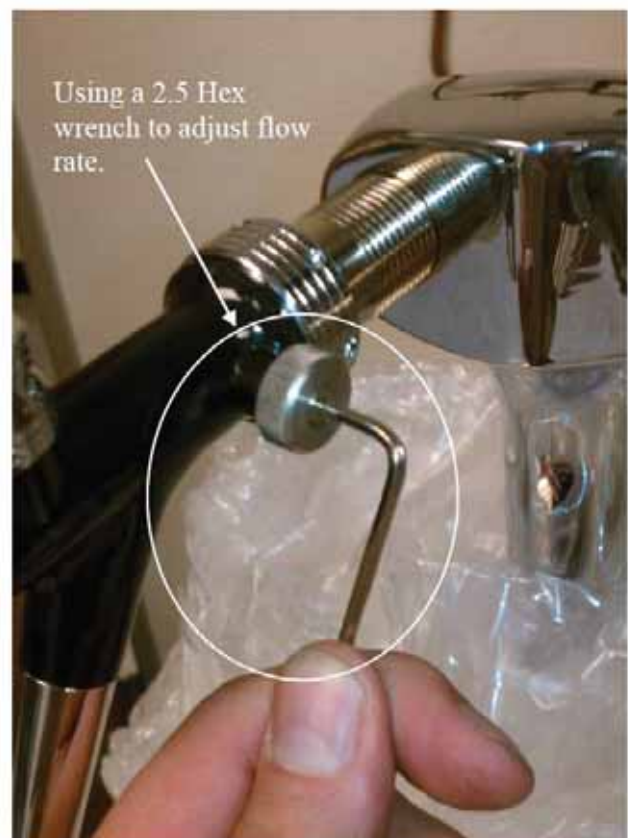
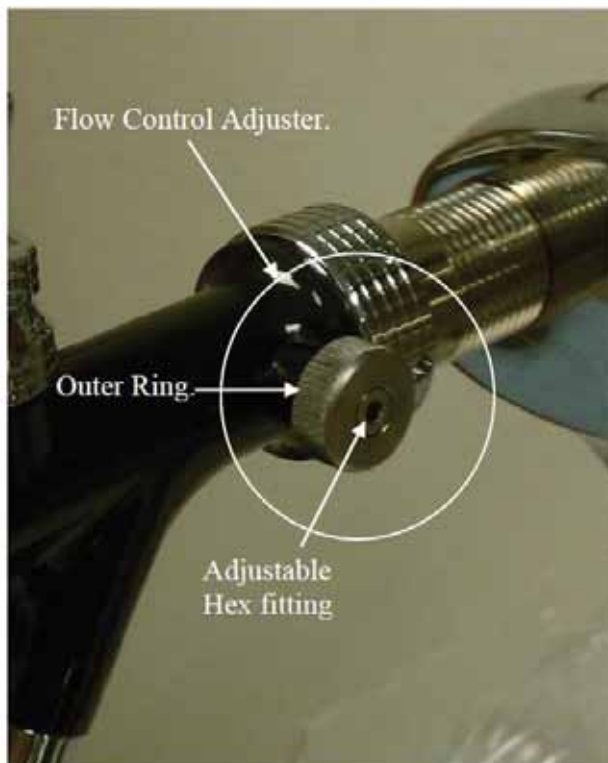

CHAPTER V

SERVICE AND MAINTENANCE

This chapter describes service and maintenance procedures to be performed on CR units and related components.

PERIODIC INSPECTION AND CLEANING

1. If water flow is slowed up or trickling out:
 - a. Check the flow rate of water out of the water filters. The filters will begin to clog as they collect dirt and debris, which indicates its time to change them.
 - b. Check that the compensator flow adjustment arm on the faucets turned to wide open (this is when the arm is in a horizontal position).
 - c. Check that the ice bank inside water bath is not formed over the center water coils.

Daily:

1. Clean the beverage dispensing area.
2. Check that Faucet handles, bonnet nut, couple nut on Faucet are all tight and leak free. Hand tighten and check that handle releases back to closed position.
5. Remove and clean nozzles and all exposed areas on valves.
6. Wipe exterior of unit with moist towel and buff dry. Stainless cleans well with carbonated water.
7. Check the water filter and water pressure.

Weekly:

2. Check Air Filter and condenser coil for obstructions or dirt. Clean if dirty.

Monthly:

1. Clean Air Filter and check condenser fins to make sure the refrigeration unit has adequate airflow and free from dust and dirt.
2. Inspect components of cooling unit water bath for cleanliness.
2. Check entire system for leaks or damaged components. Repair as necessary.
3. Check the inlet water lines, if any discoloration such as green or black can be seen they system should be sanitized.

CR-UCW CABINET MAINTENANCE

Periodically wash all external surfaces of CR-UCW cabinet to remove dust, rinse with clean water, then wipe dry with a clean soft cloth. DO NOT USE ABRASIVE TYPE CLEANERS. Clean Air filter frequently.

CR-1SW CABINET MAINTENANCE

The CR-1SW exterior finish is a mirrored stainless steel. Windex cleans it nicely without leaving behind streaks. Wipe the top and louvers clean of dust. DO NOT USE ABRASIVE TYPE CLEANERS OR SCRUB PADS.

CLEANING AIR FILTER AND CONDENSER COIL

IMPORTANT: Air circulation through the condenser coil is required to cool the compressor. Air is drawn in through the Air filter on the outside of the chiller, then through the condenser coil and exhausted out grills on the top of unit. Restricting air circulation through the cooling unit will decrease its cooling capacity.

NOTE: Clean the Air filter when a visible layer of dust or dirt can be seen.

1. Remove Air Filter by lifting it up and out of the slots it sits in
2. Use a brush to wipe off dust or compressed air to blow the dust off
3. Once clean replace by sliding the filter down into the slots.

NOTE: Cleaning condenser coil should be done during non-use periods.

1. Unplug refrigeration unit power cord from electrical socket.
2. Remove service panels.
3. Vacuum or use a soft brush to clean fins of condenser coil. Use low-pressure compressed air or CO₂ gas to blow through condenser fins. This should only be performed after normal business hours to prevent dust contamination. A damp cloth on backside of condenser coil will prevent some dust contamination
4. Replace service panels.
5. Plug the Crysalli unit's power cord in electrical socket and turn back on.

CHECKING / CHANGING WATER BATH

Semi-Annually check water level in water bath. If it is low, more water should be added for maximum product cooling. Before adding more water, water bath and ice bank should be checked for excessive mineral deposit build up.

NOTE: The water in water bath should be changed and all components in water bath should be cleaned as often as necessary to keep it clean. A convenient time to perform this operation is when the system is being sanitized.

1. Unplug refrigeration unit power cord from electrical socket.
2. Remove lid from unit.
3. Look down into water bath (if necessary, use flashlight) and inspect water bath, ice bank and all components for cleanliness. Water, ice bank and all components should be clear and free of foreign particles. If ice bank is clear of foreign particles, it does not have to be melted down. Proceed to step 10, if foreign particles are present in the ice bank, proceed to step 4.
4. Siphon out water with short hose or pull out over flow standpipe.
5. Allow ice bank to melt. WARM NOT HOT water may be used to speed melting.

CAUTION: Never use an ice pick or other sharp instruments to remove ice from evaporator coil. Such practice can result in puncture to the refrigeration circuit.

6. Use fiber brush and carefully clean mineral deposit from all components.
8. Wash evaporator coil with a mild soap solution. Copper cleans well with mild solution of citric acid (1 cup of citric acid for 2 gallons of water). Stainless steel cleans well with carbonated water. Then rinse with clean water.
9. Rinse out water bath with clean water until water running out of siphon hose is clean.
9. Insert standpipe in drain hole
10. Fill water bath to top of standpipe.
11. Replace lid.
12. Plug refrigeration unit power cord in electrical socket.

WATER PUMP MAINTENANCE (RECOMMEND THIS BE DONE BY A TRAINED SERVICE TECH). APPLICABLE ONLY FOR MODELS CONFIGURED WITH AN INTERNAL BOOSTER PUMP.

Warning: The water pump inlet strainer screen must be inspected and serviced at least once a year under normal circumstances or after any disruptions (plumbing work, earthquake, etc.), to the water supply systems that might cause clogged flow of water through system. Water pump with no screen or a defective screen in the strainer would allow foreign particles into water system and create a health hazard.

1. Unplug power cord from electrical socket.
2. Shut off plain water supply to water pump by closing shutoff valves in water supply line.
3. Gain access to water bath.
4. Release any pressure in the system.
5. Go to carbonator motor "Y" strainer and remove screen retainer.
6. Pull screen retainer and water strainer screen out of water pump port.
7. Clean any sediment from screen retainer and water pump port.
8. Inspect water strainer screen for holes, restrictions, corrosion, and other damage. **A water strainer screen should always be used, otherwise particles could damage pump and foul the double check valve.**
9. Check "O" ring on screen retainer. Replace worn or damage "O" ring

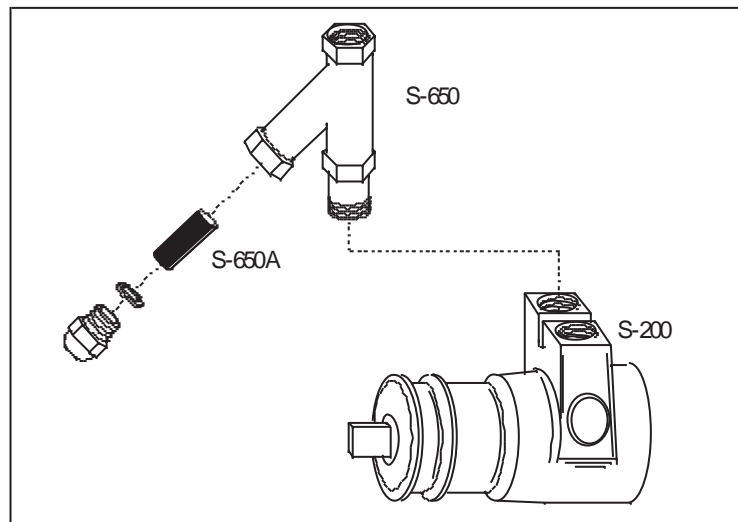

WATER PUMP, "Y" STRAINER & SCREEN

CHANGING WATER FILTER CARTRIDGE

Follow manufacturer's instructions for water filter, note importance of properly flushing filters.

ADJUSTMENTS

The compensator flow control arm on the Speedy Faucets regulates the flow of water out of the faucets. When this regulating arm is the horizontal position, it is full open. By turning it up or down you will restrict the flow rate of the water. A full quarter turn can completely stop the water flow if incoming water pressure is low enough.

SANITIZING PROCEDURES

Your local health department rules and general area cleanliness should determine the frequency at which the unit should be sanitized.

EQUIPMENT REQUIRED:

When using an Everpure Water filter system, use the JT Flushing/Sanitizing Cartridge (EV9608-00) and Plug, instructions included with cartridge.

1. Fill JT cartridge with sanitizing agent and install into the last position in filter manifold, plug front position with filter plug.
2. Turn the water back on and the CO2 off.
3. Pull valves on Crysalli to draw water and sanitizer through into another bucket.
4. Flush each line for at least 1 minute (hold both faucets open and dispense into a bucket) until water consistency and clarity changes back (flush until free of detergent), continue pulling water for to thoroughly flush out.
5. Turn water back off and replace JT cartridge and Plug with new Everpure water filters and flush them.
6. Dry the JT Cartridge and replace back in storage for use next time.

Manual cleaning (to be done by service tech):

1. Stainless Steel containers (product tanks), or large volume container.
2. CO2 Supply if applicable (Same as used with dispensing unit).
3. Cleaning Agent.
4. Sanitizing Solution.
5. Phenolphthalein.

NOTE: One recommended cleaning agent and sanitizing agent is manufactured by:

MT. HOOD CHEMICAL CORP.
4444 N.W. Yeon Avenue
Portland, Oregon 97210

Trade names are:

CROWN - 12.5% SODIUM HYPOCHLORITE BLEACH

Use STAR at 18 oz. per 1 gallon of water yields 2% Sodium Hydroxide Solution.

1. Visually inspect valve by removing nozzle and inspecting nozzle and valve cavity. Clean nozzle with cleaning agent, then sanitizing solution, then with potable water. Inspect valve cavity and if dirty clean with soft bristle brush. Clean exteriors of valve with a soft cloth and warm water. Replace valve nozzle then go to step #3.
2. Disconnect water inlet line at a point in the exposed tubing. Leaving enough length to place in a bucket.
3. Put inlet tubing in a bucket full of water and sanitizer.
4. Turn unit on and pull product from both valves into another bucket to discard.
5. Run sanitizer through until empty.
6. Replace bucket with clean rinse water and run through system.
7. Reconnect inlet water line and turn the water back on.
8. Taste the beverage to verify that there is no off taste.

TROUBLE SHOOTING

IMPORTANT: Only qualified personnel should service the CR unit and components.
This guide cover both the standard Carbonated and Still Water models

WARNING: To avoid personal injury and or property damage, always disconnect electrical power, shut off plain water and CO2 supplies before starting any repairs. If repairs are to be made to the carbonated water system, bleed carbonated water system pressure before proceeding. If repairs are to be made to syrup system, remove quick disconnects from syrup tanks, or remove QCD from BIB, then bleed system pressure before proceeding.

CARBONATOR

Trouble		Probable Cause		Remedy
Water pump motor will not operate	1. 2. 3. 4. 5.	Inoperable water pump/ motor. Overheated motor (cut off by thermal overload protector). Electrode inside carbonator tank defective. L.L.C. assembly Inoperable. Loose electrical connection and/or open electrical circuit. Defective pump protector, S-103	1. 2. 3. 4. 5.	Replace water pump/ motor. Check for proper line voltage. Allow motor time to cool. Replace carbonator tank electrode. Replace L.L.C. assembly. Tighten connection and/or repair open circuit. Check line voltage. Replace pump protector
Water pump motor will not shut off	1. 2. 3. 4. 5.	Defective water pump. Electrode inside carbonator tank defective. L.L.C. assembly inoperable. Loose electrical connection and or open electrical circuit. Carbonated water leak.	1. 2. 3. 4. 5.	Replace water pump. Replace carbonator tank electrode. Replace L.L.C. assembly. Tighten connection and or repair open ground circuit. Find and repair leak.
Water Pump motor will not shut off and pressure relief engaged	1. 2.	Electrode inside carbonator does not sense ground. L.L.C. assembly inoperable.	1. 2.	Replace defective electrode or check and tighten ground connection at control box. Replace L.L.C. assembly.
Short cycling of water pump motor	1. 2. 3.	Ground connection loose or disconnected. Electrode inside carbonator tank defective. Carbonated water leak in system. L.L.C. assembly inoperable.	1. 2. 3.	Attach or tighten ground connection. Replace carbonator tank electrode. Repair carbonated water leak. Replace L.L.C. control assembly.
Water pump capacity to low	1. 2. 3. 4.	Inlet water volume supply to low. Water motor/pump worn out. Kinked or restricted water supply line. Foreign object in water pump or restriction to water pump.	1. 2. 3. 4.	Increase diameter of supply line, install holding tank. Replace water pump. Clear or replace restricted water supply line. Clear restrictions and check pump strainer for debris.
Water pump operates but water pump does not pump	1. 2. 3. 4.	Water supply to low or turned off. Inoperative water pump. Water supply filter clogged. Water pump strainer clogged.	1. 2. 3. 4.	Inlet water supply must be a minimum of 3/8". Replace water Pump. Replace filter. Clean water pump strainer.

Frozen water bath	<ol style="list-style-type: none"> 1. 2. 3. 4. 	<ol style="list-style-type: none"> Bad ice bank control. Refrigerant leak causing undercharge. Defective agitator motor. Dirty water bath. 	<ol style="list-style-type: none"> 1. 2. 3. 4. 	<ol style="list-style-type: none"> Replace bad ice bank control. Repair leak, evacuate and recharge. Replace defective agitator. Melt ice, empty & clean bath. Replenish w/fresh water.
Cooling or condensing unit non-operational	<ol style="list-style-type: none"> 1. 2. 3. 4. 5. 6. 7. 8. 	<ol style="list-style-type: none"> No electrical power. Defective ice bank control. Dirty condenser unit. Improper voltage/amperage Loss of refrigerant. Bad overload and relay. Compressor bad. Restriction (pinched or crimped line). 	<ol style="list-style-type: none"> 1. 2. 3. 4. 5. 6. 7. 8. 	<ol style="list-style-type: none"> Plug power cord into electrical box. Check on/off switch. Replace ice bank control. Clean condenser unit w/vacuum cleaner. Check for proper voltage/amperage. Repair leak and replenish refrigerant. Replace overload and relay Replace compressor. Repair, straighten or replace defective line.
Agitator motor not operating	<ol style="list-style-type: none"> 1. 2. 3. 4. 	<ol style="list-style-type: none"> Agitator propeller obstructed or lost. Low voltage. Loose, unplugged, or broken wiring. Bad agitator motor. 	<ol style="list-style-type: none"> 1. 2. 3. 4. 	<ol style="list-style-type: none"> Remove obstruction or re-Attach propeller. Voltage must be at least 110 volt at terminals. Tighten connection or replace broken wiring. Replace agitator motor.
Compressor does not operate	<ol style="list-style-type: none"> 1. 2. 3. 4. 5. 6. 7. 8. 	<ol style="list-style-type: none"> No power source. Electrical power to cooling unit turned off. Low voltage. Loose, disconnected, or broken wire. Inoperative ice bank control. Inoperative overload protector or start relay. Inoperative compressor. Full ice bank. 	<ol style="list-style-type: none"> 1. 2. 3. 4. 5. 6. 7. 8. 	<ol style="list-style-type: none"> Plug power cord to electrical box. Check line voltage. Turn on power switch to unit. Voltage must be at least 110 V at compressor terminals at start. Tighten connection or replace broken wiring. Replace ice bank control. Replace defective part. Replace compressor. Refrigeration not called for.
Compressor works continuously but does not form sufficient ice bank	<ol style="list-style-type: none"> 1. 2. 3. 4. 	<ol style="list-style-type: none"> Cooling capacity is exceeded by over drawing. Cooling unit located in excessively hot area. Air circulation through condenser coil is restricted Loss of refrigerant or in-sufficient charge. 	<ol style="list-style-type: none"> 1. 2. 3. 4. 	<ol style="list-style-type: none"> Reduce amount of drinks taken per given time of install higher volume unit. Relocate cooling unit. Check and if necessary, clean condenser coil. Repair leak and/or recharge with sufficient refrigerant.

Note: Ice bank freezes from bottom of evaporator upward. A refrigerant leak or insufficient charge might show ice at bottom and not at top of evaporator.				
Compressor will not stop after sufficient ice bank is produced	1.	Ice bank control capillary tube kinked or broken.	1.	Replace ice bank control.
	2.	Ice bank control stuck in closed position.	2.	Replace ice bank control.
Note: During overload protector shut off condenser fan motor will continue to work. Otherwise, troubleshooting condenser fan motor problems is the same, as "Compressor does not operate", paragraph in addition to the following.				
Condenser fan motor not operating	1.	Electrical cord loose or disconnected from condenser fan motor or compressor terminals.	1.	Tighten connections or replace cord.
	2.	Fan blade obstructed.	2.	Remove obstruction.
	3.	Inoperative condenser fan motor.	3.	Replace condenser fan motor.
No water being dispensed	1.	Plain water inlet supply shutoff closed.	1.	Open plain water inlet supply line shut off valve.
	2.	Water filter fouled/clogged.	2.	Replace filter or cartridge.
	3.	Pinched or crimped line.	3.	Repair defective line.
	4.	Loose electrical connection, 24 volt.	4.	Tighten connection and or repair open circuit.
	5.	Water pump motor worn out or damaged.	5.	Replace motor.
	6.	Water pump worn out or damaged.	6.	Replace water pump.
	7.	Frozen water bath.	7.	See "Frozen water bath".
Volumes of CO2 to low in finished product	1.	High-pressure regulator out of adjustment.	1.	Adjust high-pressure regulator as instructed.
	2.	CO2 cylinder empty.	2.	Replace CO2 cylinder.
	3.	Water, oil, or dirt in CO2 supply.	3.	Clean contaminated CO2 system, (lines, regulator, etc.) and sanitize as instructed.
	4.	Temperature above quality limits.	4.	See refrigeration/machine specifications vs. volume requirements.

<p>Dispensed product makes foam as it leaves dispensing valve</p>	<ol style="list-style-type: none"> 1. 2. 3. 4. 	<p>Pressure of CO2 to high.</p> <p>Dirty nozzle and valve cavity.</p> <p>Temperature above quality limits.</p>	<ol style="list-style-type: none"> 1. 2. 3. 4. 	<p>Adjust high-pressure regulator as instructed.</p> <p>Clean contaminated nozzle and sanitize as instructed. See refrigeration/machine specifications vs volume requirements.</p>
<p>Dispensed product comes out clear but foams in cup or class</p>	<ol style="list-style-type: none"> 1. 2. 	<p>Oil film or soap scum in cup or glass.</p> <p>Ice used for finished drink is subcooled.</p>	<ol style="list-style-type: none"> 1. 2. 	<p>Use clean cups and glasses. Check sanitizer rinse ratio on dish washer.</p> <p>Do not use ice directly from freezer. Allow ice to become "wet" before using. Note; crushed ice also causes foaming of beverage. Carbonation is released on sharp edges of the ice.</p>

CARBONATION TROUBLE SHOOTING FLOW CHART #1

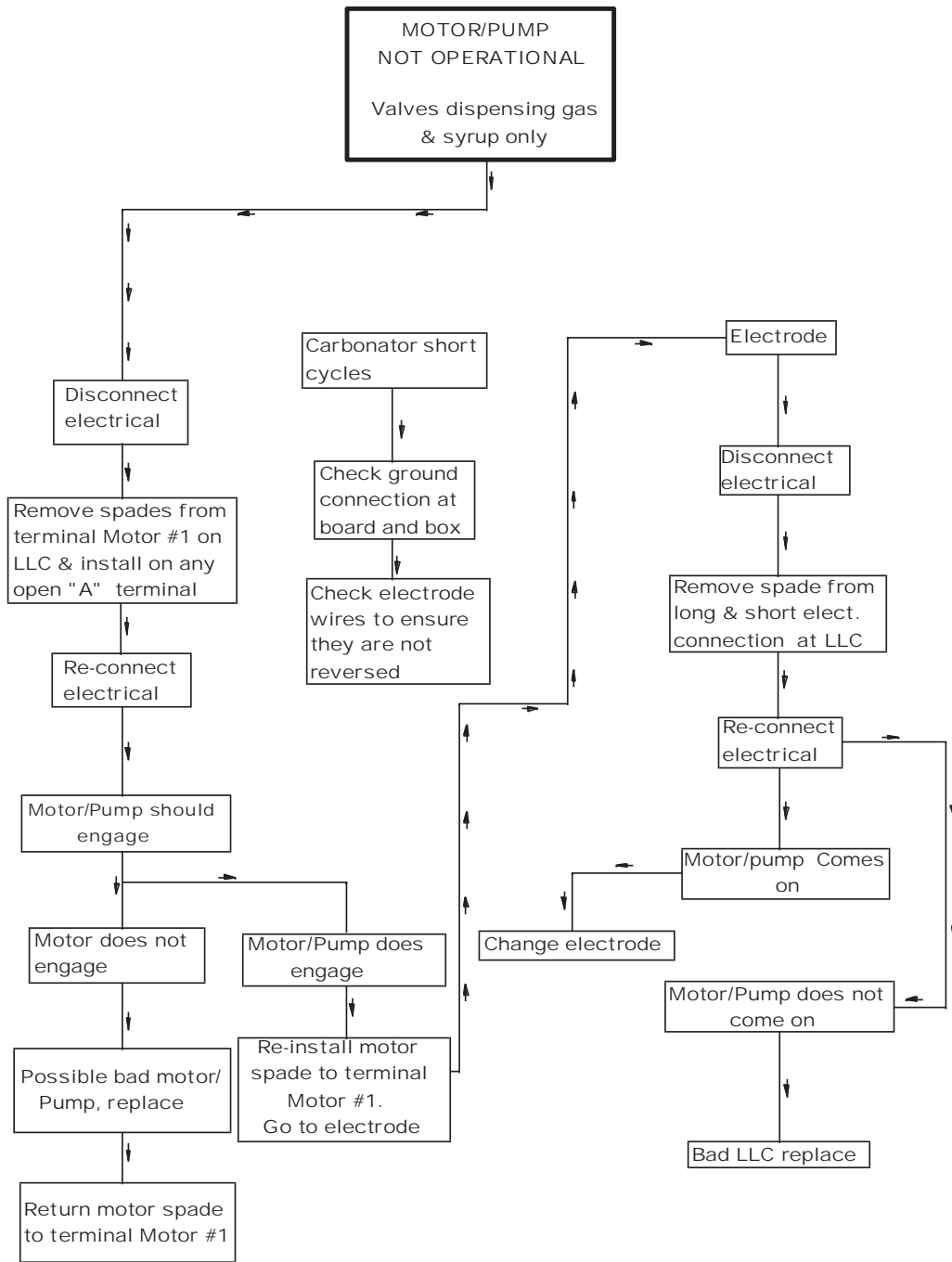



Limited Express Warranty

Crysalli Artisan Water Systems (hereinafter referred to as Crysalli) warrants for a period of 12 months from installation date (except as limited below) that new Crysalli water systems, towers and faucets (hereinafter referred to a Product) manufactured by ICI for Crysalli shall be free of defects in material or workmanship under normal and proper use and maintenance as specified by Crysalli and upon proper installation and start-up in accordance with the Quick Install Guide and Owners Manuals. Any accompanying water filtration system is warranted by the Manufacture of that product only, not by Crysalli, ICI or WPD.

The obligation of Crysalli under this limited express warranty is limited to the repair or replacement of parts, components, or assemblies that in the opinion of Crysalli are defective. This warranty is further limited to the cost of parts, components or assemblies and standard straight time labor charges at the servicing location. Replacement parts are warranted for 90 days or the balance of the original warranty period, whichever is longer. The foregoing constitutes Crysalli's sole obligation and the consumer's exclusive remedy for any breach of this warranty. Crysalli's liability under this warranty shall in no event be greater than the actual purchase price paid by the consumer for the Product. Additional expenses including, without limitation, service travel time, overtime or premium labor charges, accessing or removing the Product, or shipping are the responsibility of the consumer.

The foregoing limited express warranty shall not apply to costs for: (1) periodic or routine maintenance including water filter change outs, (2) repair or replacement of the Product or parts due to normal wear and tear, (3) defects or damage to the Product or parts resulting from clogged water filters, misuse, abuse, neglect or accidents, (4) defects or damage to the Product or parts resulting from improper or unauthorized alterations, modifications, or changes; (5) defects or damage to any Product that has not been installed and/or maintained in accordance with the Owners Manual, Quick Install Guide or technical instruction provided by Crysalli, ICI or WPD; and (6) any work being performed by non-authorized service agents.

THIS LIMITED EXPRESS WARRANTY IS IN LIEU OF ALL OTHER WARRANTIES OR GUARANTEES OF ANY KIND, EXPRESSED OR IMPLIED, INCLUDING ANY IMPLIED WARRANTY OF MERCHANTABILITY OR FITNESS FOR A PARTICULAR PURPOSE. IN NO EVENT SHALL CRYSTALLI, WPD, OR ICI BE LIABLE FOR ANY SPECIAL, INDIRECT, INCIDENTAL OR CONSEQUENTIAL DAMAGES. Upon the expiration of the warranty period, Crysalli's liability under this limited express warranty shall be terminated. The foregoing limited express warranty shall constitute the sole liability of Crysalli, WPD and ICI and the exclusive remedy of the customer or user.

To secure prompt and continuing warranty service, the warranty registration card or online form must be completed and sent to Crysalli within thirty (30) days from install date. Complete the following registration card and send to Crysalli/WPD to below address. Retain a copy for your record.

Name of Customer/Business & Address: _____

Phone: _____

Distributor/Dealer: _____

Model Number: _____ Serial Number: _____

Install Date: _____ Install Company: _____

Crysalli Artisan Water
1739 Sabre St, Hayward, CA 94545
Phone: 510-732-0100 • Fax: 510-732-0155
Web site: www.crysalli.com